

## SuperSigma2 QRM for AC induction motors



This user manual details the features of the [standard controller range](#):

(for more detailed information contact DMC)

1. AC range for AC Induction Motors 24-96V, 250-600Arms

### Modification History:

Revision	Issue Date	Author	Changes
01.00.01	09-09-2014	RP	Style changes and updated parameter tables
01.00.02	10-10-2014	YS / RP	Updated parameter tables structure
01.00.03	20-10-2014	AJ / RP	Updated parameter ranges & sensor supply 5V and 12V swapped
01.00.04	24-10-2014	RP	Improved auto tuning description
01.00.05	23-12-2014	RP	General update and CAN description added
01.00.06	16-04-2015	RP	Match latest firmware V02.03.xx and added iGauge schematic
01.00.07	12-10-2015	RP	Firmware V02.05.00 - Shared line contactor & control via CAN & new menu structure
01.00.08	29-10-2015	RP	Firmware V02.05.02 – added parameter 23 to the AC motor setup menu
01.00.09	20-04-2016	RP	Match Firmware V02.06.01

# Contents

<b>1</b>	<b>DMC PHILOSOPHY – INTRODUCTION .....</b>	<b>4</b>
<b>2</b>	<b>SUPERSIGMA2 VARIANTS .....</b>	<b>5</b>
<b>3</b>	<b>CONTROLLER FEATURES .....</b>	<b>6</b>
<b>4</b>	<b>TECHNICAL SPECIFICATIONS .....</b>	<b>7</b>
4.1	ELECTRICAL.....	7
4.1.1	<i>Voltage specifications:.....</i>	<i>7</i>
4.1.2	<i>Current specifications: .....</i>	<i>7</i>
4.2	ENVIRONMENTAL.....	7
4.3	MECHANICAL.....	7
<b>5</b>	<b>INSTALLATION INSTRUCTIONS .....</b>	<b>8</b>
5.1	SAFETY .....	8
5.2	MECHANICAL INSTALLATION AND COOLING.....	8
5.3	POWER WIRING.....	8
5.4	LIGHT WIRING .....	8
5.5	SPEED SENSOR CABLING .....	8
5.6	CONTACTORS.....	8
5.7	FLASHING NEW SOFTWARE .....	9
5.8	POWER UP DELAY .....	9
<b>6</b>	<b>EMC GUIDELINES .....</b>	<b>9</b>
6.1	POWER CABLES .....	9
6.2	SIGNAL CABLES .....	9
6.3	CONTROLLER .....	9
<b>7</b>	<b>CALIBRATOR .....</b>	<b>10</b>
7.1	THE CALIBRATOR .....	10
7.2	CALIBRATOR MAP .....	10
7.3	DMC PC PROGRAMMER .....	10
<b>8</b>	<b>DASHBOARD DISPLAY.....</b>	<b>11</b>
8.1	GENERAL INFORMATION.....	11
8.2	DISPLAY SETUP MENU.....	11
8.3	DISPLAY FEATURES SETUP .....	11
8.4	DISPLAY ICONS.....	12
<b>9</b>	<b>PARAMETERS.....</b>	<b>13</b>
9.1	MENU 1 “TRACTION ADJUSTMENTS” .....	13
9.1.1	<i>Neutral braking setup options .....</i>	<i>14</i>
9.1.2	<i>Neutral braking setup in speed control mode (control mode 0).....</i>	<i>14</i>
9.1.3	<i>Neutral braking setup in torque control mode (control mode 1).....</i>	<i>14</i>
9.1.4	<i>Neutral braking setup in torque control mode (control mode 2).....</i>	<i>14</i>
9.1.5	<i>Hill Hold .....</i>	<i>14</i>
9.2	MENU 1 “PUMP ADJUSTMENTS” .....	15
9.3	MENU 2 “STATUS” .....	16
9.3.1	<i>Status tables .....</i>	<i>17</i>
9.3.2	<i>Drive and brake limits tables .....</i>	<i>17</i>
9.4	MENU 3 “CONTROLLER SETUP” .....	18
9.4.1	<i>Controller Setup for Traction .....</i>	<i>18</i>
9.4.2	<i>Controller Setup for Pump .....</i>	<i>19</i>
9.5	AC MOTOR AUTO TUNING.....	20

9.5.1	<i>Setting up auto tuning</i> .....	20
9.5.2	<i>Menu 4 "AC Motor Auto Tuning"</i> .....	21
9.5.3	<i>Initiating auto tuning</i> .....	22
9.5.4	<i>Auto tuning errors</i> .....	23
9.5.5	<i>Recalculation</i> .....	23
9.6	MENU 5 "AC MOTOR SETUP" .....	24
9.7	MENU 6 "AC MOTOR ADVANCED" .....	25
9.8	MENU 7 "LIMITS SETUP" .....	26
9.9	MENU 8 "BDI" BATTERY DISCHARGE INDICATOR.....	27
9.10	MENU 9 "CAN BUS SETUP" .....	27
9.11	MENU 10 "FAULT LOG" .....	28
9.13	MENU 11 "TEST" .....	29
9.13.1	<i>Test menu for Traction</i> .....	29
9.13.2	<i>Test menu for Pump</i> .....	30
9.14	MENU 12 "DEBUG" .....	31
9.15	MENU 13 "ABOUT" .....	31
9.16	AVAILABLE APPLICATION NOTES .....	31
9.17	THERMAL MOTOR MANAGEMENT & PERFORMANCE TABLE.....	32
9.17.1	<i>Current roll back on motor temperature</i> .....	32
9.17.2	<i>Option to disable current roll back functions</i> .....	32
<b>10</b>	<b>DIAGNOSTICS</b> .....	<b>33</b>
10.1	GENERIC AC MOTOR MODULE SUB ERROR CODES.....	36
<b>11</b>	<b>GRAPHICS &amp; SCHEMATICS</b> .....	<b>37</b>
11.1	ACCELERATOR CHARACTERISTICS.....	37
11.2	CONTROLLER THERMAL CUTBACK CHARACTERISTIC .....	37
11.3	LIGHT WIRING AC TRACTION .....	38
11.4	LIGHT WIRING AC PUMP .....	39
11.5	CAN BUS WIRING .....	40
11.5.1	<i>CAN bus wiring example with DMC Display:</i> .....	40
11.5.2	<i>CAN bus wiring example without DMC Display:</i> .....	40
11.6	IGAUGE DISPLAY – CONNECTION DIAGRAM.....	41
11.7	POWER WIRING .....	41
<b>12</b>	<b>MECHANICAL DRAWINGS</b> .....	<b>42</b>
12.1	SUPERSIGMA2 CONTROLLERS .....	42
12.2	DMC ADVANCED DISPLAY.....	42
<b>13</b>	<b>CONTACT INFORMATION</b> .....	<b>43</b>

# 1 DMC Philosophy – Introduction

DMC (Digital Motor Control) GmbH, is a company with a dedicated team of individuals with many years' experience in the design, manufacture, sales and aftermarket support of controllers predominately utilised in the electric vehicle industry. The Company has been formed with enthusiasm and professionalism to create and develop unique products for this particular "niche" industry where specialist knowledge and experience are essential for success.

A full range of associated accessories and support infrastructure completes the DMC service. To conclude, a fusion of creative thinking, collective experience and latest state of the art technology, has produced what we believe to be the most flexible and thermally advanced controller ranges available in the market place to date.

## Next Generation: The SuperSigma2 Controller Range

After the success of the Sigmadrive controller range, DMC has developed a new controller range, specially designed to control AC induction and PMAC (PMS) motors, running on nominal battery voltages in the range of 24V up to 120V, at nominal powers up to 30kW and peak powers up to 60kW.

The power board design fundamentals are similar to the previous Sigmadrive design, combining superior heat sinking of components and connections with unmatched vibration protection. The mechanical design is improved to IP65 and we incorporated the industry standard 35 way AMP-seal connector.

Nonetheless we had to leave the single PCB design philosophy in favour of a separate logic PCB to utilise state of the Art 32bit microcontroller technology that enables us to offer features required for today's vehicle control. A completely new motor control module is introduced, using flux vector motor control for both AC induction and PMAC.

New Features on SuperSigma2 are for example fully automated tuning of AC induction motors without the need for manual fine tuning or using a PC. The advanced auto tuning algorithms allow motor tuning even if the motor is installed on the vehicle. Just entering the motor name plate data into the controller tuning menu is enough to obtain optimal tuning results. Even when the motor name plate data is unknown it is possible to get the system running smoothly!

On PMAC we introduce automated motor sensor setup for 8bit sin/cos absolute position encoders and hall sensors, which significantly eases the production of PMAC motors, eliminating the costly need for adjusting sensor offsets.

Vehicle constructors now have the choice to use control via CAN or use the flexibility of software selectable active high or active low inputs. Optimized interfacing with battery management systems completes the SuperSigma2 controller range, allowing limiting battery current, especially useful for vehicles using Lithium batteries.

## Sigmadrive Controller Range

The first generation of DMC controllers, today known as the 'Sigmadrive controller range' was designed in the year 2000. Utilising revolutionary power heat sinking technology called IMS (Insulated Metal Substrate) a new generation of highly efficient controllers for all popular motor types is offered from a single core design, in the 24V - 96V, 1KW - 24KW power range. Using 'flash memory' in the control electronics coupled with a unique design architecture, all powers and motor types including AC, PMS (PMAC), SEM, PM4 and Series, can be accommodated within 3 standard power frames. Particular attention has been placed on providing high-resolution control circuitry and software, to provide fully optimised, highly efficient motor control.

The principle advantage of IMS technology (which can be visualised as a metal PCB) is that cost effective SMD Mosfet power devices can be mounted and soldered directly onto the IMS PCB, which provides immediate and excellent 'integral' heat sinking. Consequently, reliability and efficiency are significantly enhanced due to the power switching devices running cooler and therefore inherently more efficiently. This approach also leads to significantly improved continuous power delivery (1 hour current rating), as a ratio to peak power, with the controllers continuous rating normally being one of the most important aspects in determining the vehicles performance.

By using an innovative patented technique, DMC has fully exploited IMS technology to realise a unique controller design. The construction provides manufacturing simplicity and reliability by removing the need for any interconnections and using a minimal number of mechanical and electronic components. This gives a totally robust and environmentally sealed, space efficient controller.

©2015 DMC GmbH

## 2 SuperSigma2 variants

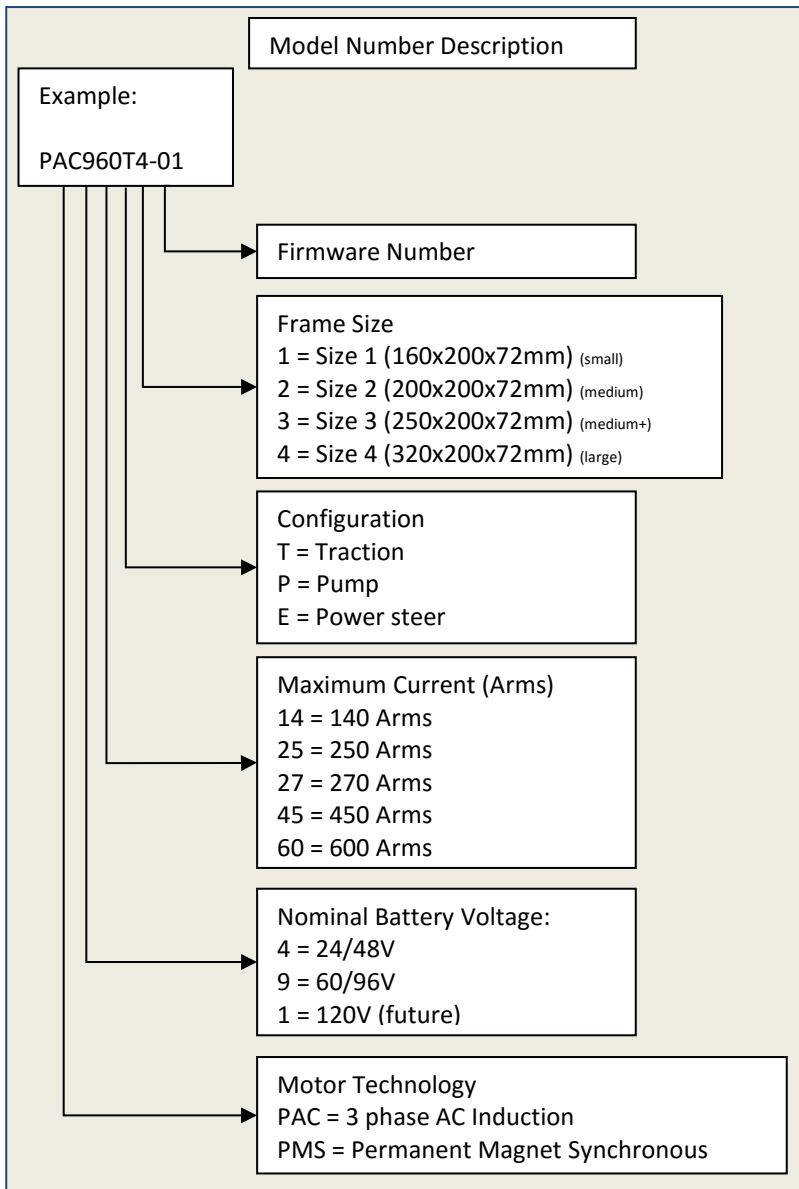

Model Nr.	Power
<b>AC Traction</b>	
PAC960T4-**	60-96V 600Arms
PAC945T3-**	60-96V 450Arms
PAC927T2-**	60-96V 270Arms
PAC914T1-**	60-96V 140Arms
PAC460T3-**	24-48V 600Arms
PAC445T2-**	24-48V 450Arms
PAC425T1-**	24-48V 250Arms
<b>AC Pump</b>	
PAC960P4-**	60-96V 600Arms
PAC945P3-**	60-96V 450Arms
PAC927P2-**	60-96V 270Arms
PAC914P1-**	60-96V 140Arms
PAC460P3-**	24-48V 600Arms
PAC445P2-**	24-48V 450Arms
PAC425P1-**	24-48V 250Arms
<b>PMS Traction</b>	
PMS960T4-**	60-96V 600Arms
PMS945T3-**	60-96V 450Arms
PMS927T2-**	60-96V 270Arms
PMS914T1-**	60-96V 140Arms
PMS460T3-**	24-48V 600Arms
PMS445T2-**	24-48V 450Arms
PMS425T1-**	24-48V 250Arms
<b>PMS Pump</b>	
PMS960P4-**	60-96V 600Arms
PMS945P3-**	60-96V 450Arms
PMS927P2-**	60-96V 270Arms
PMS914P1-**	60-96V 140Arms
PMS460P3-**	24-48V 600Arms
PMS445P2-**	24-48V 450Arms
PMS425P1-**	24-48V 250Arms

### 3 CONTROLLER FEATURES

Feature	
Number of digital switch inputs.	7
Number of digital inputs, sensor related	3
Number of analogue inputs	6
Number of contactor driver outputs (2.5 Amps as limited by interconnect current carrying capability) (build in contactor coil suppression)	3
Number of low power output (Can be amplified with a DMC external driver module 830/DRV)	1
24V - 120V Operation	✓
100% on Mosfet technology	✓
IMS power PCB for superb thermal conduction	✓
Cooled power terminals	✓
Updatable firmware / flash memory, easy software updates	✓
Environmental protection IP65	✓
Powerful, State of the art 32 bit microprocessor control	✓
High frequency 16kHz (Silent Operation)	✓
Internal watchdog monitoring microprocessor operation	✓
Arc less contactor switching and built in coil suppression	✓
Low impedance, active low inputs switched to B-ve	✓
Active high inputs available on request	✓
Thermally compensated current limit	✓
Selectable accelerator characteristics	✓
Adjustable creep speed	✓
Seat switch timer	✓
Power steer timer	✓
Electro brake timer	✓
Belly switch operation	✓
Regenerative braking	✓
Direction braking proportional to accelerator position	✓
Braking in neutral	✓
Braking with brake pedal – proportional or switched	✓
Under and Over-voltage protection	✓
Accelerator wire off detect	✓
Inching facilities	✓
Short circuit and open circuit contactor detect	✓
3 traction cutback speeds	✓
6 Pump speeds with Additive & Priority	✓
Input to disable pump operation	✓
Independent power steer speed and compensation settings	✓
Hardware and Software fail-safe systems	✓
+ 12V or +5V selectable output pin supply	✓
Diagnostics with LED indication	✓
Remote diagnostic LED	✓
Adjustments made via a calibrator or PC programmer	✓
CAN Open compatible	✓
Hours count displaying key & pulsing hours on calibrator	✓
BDI on Calibrator	✓
Dashboard display connectable	✓
Easy to use 'icons' for display information	✓
Resettable Service and Fault logs	✓
Setup menu on calibrator to enable various options	✓

## 4 TECHNICAL SPECIFICATIONS

### 4.1 Electrical

#### 4.1.1 Voltage specifications:

Model	Nominal battery voltage	Absolute operating voltage range	Reduced braking voltage levels (F4)	High Voltage cut out level (F22)
PXX4xx-XX	24 V – 48 V	12.0 V – 72.5 V	60.0 V – 67.5 V	70 V
PXX9xx-XX	60 V – 120 V	12.0 V – 144.0 V	130.0 V – 138.5 V	140 V

Note: These voltage levels are used to set the voltage levels in the Limits menu.

#### 4.1.2 Current specifications:

Model	Power	Current limit (1 min)	Continuous current 1 hour rating. Unit mounted on an sufficient heat sink, at 20°C ambient.	Controller frame size
PXX425XX	24/48V 250A	250Arms	130A	Size 1
PXX445XX	24/48V 450A	450Arms	250A	Size 2
PXX460XX	24/48V 600A	600Arms	330A	Size 3
PXX914XX	60/96V 140A	140Arms	75A	Size 1
PXX927XX	60/96V 270A	270Arms	140A	Size 2
PXX945XX	60/96V 450A	450Arms	230A	Size 3
PXX960XX	60/96V 600A	600Arms	300A	Size 4

Switching Frequency: Controller frequency is 8KHz (centre aligned PWM switching). Motor frequency 16KHz.  
 Electrical Isolation: Enclosure to any live part = 1KV. Controller internal insulation specified at >10MΩ @500V DC.  
 Reverse Battery Polarity: If line contactor installed according to the manual, yes  
 I/O details: See light wiring diagram.

### 4.2 Environmental

Impact Protection (IP): The enclosure is protected to IP65 (when AMP seal Connector fitted)  
 Vibration: 6G, 40-200Hz for 1 hour, in x, y and z planes.  
 Operating Temperature: -30°C to +40°C ambient around controller.  
 Storage Temperature: -40°C to +70°C.  
 Humidity: 95% maximum, non-condensing.  
 Humidity Resistance: Ingress protected, watertight AMP seal connector

Safety: Designed to the requirements of machine directive 2006/42/EC, safety of industrial trucks EN1175-1:1998+A1:2010, EN13849-1, UL94.  
 The vehicle manufacturer is responsible for the compliance of the complete system with the appropriate regulations.

EMC: EN61000-6-2 (industrial immunity), EN61000-6-3 (residential emissions, Class B)

### 4.3 Mechanical

Details: See mechanical drawings.  
 Enclosure: Aluminium heat sink with ABS plastic cover.  
 Power connections: Vertical Copper studs.  
     Hexagonal: Fixing torque 9.5Nm (Slot screws are recommended!)  
     Slot screw: Recommended, fixing torque 9.5Nm (Brass)  
     Bolt length: Max 20mm incl. washer and spring washer  
 Weight: Size1: 3.25kg; Size2: 4.1kg; Size3: 4.9kg; Size4: 6.2kg;

	<p><b>Always use a torque wrench when fixing the power terminals.</b>  <b>Exceeding the maximum specified torque can cause serious damage to the controller and warranty might be void.</b>  <b>Too long bolts damage the controller.</b></p>
---	---

## 5 INSTALLATION instructions

### 5.1 SAFETY

Electric vehicles can be dangerous. All testing, fault-finding and adjustment should be carried out by competent personnel. The drive wheels should be off the floor and free to rotate during the following procedures. THE VEHICLE MANUFACTURER'S MANUAL SHOULD BE CONSULTED BEFORE ANY OPERATION IS ATTEMPTED.

THE BATTERY MUST BE DISCONNECTED AND THE INTERNAL CAPACITORS MUST BE DISCHARGED BEFORE REPLACING, MODIFYING OR ATTEMPTING ANY REPAIRS OF THE CONTROLS.

Before working on the controls disconnect the battery and connect the B+ and B- controller terminals via a 10 ohm 25 watt resistor to discharge the internal capacitors.

Never connect the controller to a battery with its vent caps removed as an arc may occur due to the controller's internal capacitance when it is first connected.

### 5.2 Mechanical installation and Cooling

The controller should be bolted down to a flat (0.2mm max. Deviation) paint free surface, eventually lightly coated with a thermal transfer compound, by the 4 fixing holes provided. Care should be taken not to trap any wires, etc., under the controller. The mounting surface MUST be a substantial metal section of the vehicle for the full controller ratings to be achieved. If there is no sufficient cooling surface available, then we advise to use a ripped aluminium heat sink supported by a fan, or mount the heat sink in such a way that the driving wind cools the system.

### 5.3 Power wiring

Power connections should be made with flexible heat resisting cables of suitable cross-sectional area for the current to be carried. These should be terminated in crimped lugs attached to controller and the contactors. Note that bolts and washers are supplied for the connections on the controller. Be careful not to use too long bolts, as they can damage the PCB. A battery-disconnect switch should be used (EC Directive).

Fixing torque for power connectors M8 terminals is 9,5Nm, for M6 power connectors 9,5Nm.

The controller wiring must be completely isolated from the chassis, NEVER CONNECT B- OR B+ TO THE CHASSIS OF THE VEHICLE. On road vehicles with an 12 Volt on-board electrical system, the 12 Volt system MUST be galvanic separated from the drive power system. This can be done via a DC-DC converter that charges the 12 Volt system from the drive battery system. Always use a line contactor, controlled by the DMC controller, to enable the controller to switch off in unsafe situations.

### 5.4 Light wiring

The controller may be supplied as a stand-alone unit or pre-wired onto a base-plate with contactors etc.

Control wiring connections should be made using 0.56mm<sup>2</sup> (AWG#20) or equivalent stranded wire. The correct pressure release crimping tools MUST be used for long term connection reliability.

The main battery cable should be fused with a suitable air-break fuse. The key switch line must also be fused at a level not exceeding 10 A when using the specified Ametek or Albright contactors.

The return wiring for the accelerators should be connected to pin A10 on the controller to guarantee wire off detection..

### 5.5 Speed sensor cabling

Avoid routing the sensor cabling along with high power motor or battery cables.

Special care should be taken when connecting the screen of the motor speed sensor cable. Be sure only to connect the screen on the controller side @ pin A31). When connected also to the motor side, current will flow over the screen, disturbing the signal from the sensor to the controller, this can result in dangerous situations.

### 5.6 Contactors

The contactor mounting plane can affect performance, contactors should never be mounted with their terminal studs vertically down. For further applications information on contactors, please consult DMC GmbH in Herten.

As blow-out magnets are fitted to contactors (except 24V) ensure that no magnetic particles can accumulate in the contact gaps and cause malfunction. Ensure that contactors are wired with the correct polarity to their power terminals as indicated by the + sign on the top moulding.

The SuperSigma2 must NOT be used with permanently-connected on-board chargers or damage to the system may result. Using a change-over contactor as line contactor is a good solution to fit both the charger and the controller in the truck.



## 5.7 Flashing new software

When flashing the controller with a new software version, ALWAYS carefully check ALL parameters after flashing to be correct. Only qualified engineers are allowed to update the controllers firmware.

## 5.8 Power up Delay

At first power up the internal capacitor bank needs to be charged. The controller has a build in pre-charge resistor, and is monitoring the capacitor bank voltage. As soon as the voltage is at the required level, the line contactor will pull in. Specially at 24V systems using a Large size controller, the time delay to charge the capacitor bank can be longer.

# 6 EMC GUIDELINES

The following guidelines are intended to help vehicle manufacturers to meet the requirements of the EC directive Electromagnetic Compatibility. The SuperSigma2 controller range is designed to meet EN61000-6-2 (industrial immunity), EN61000-6-3 (residential emissions, Class B).

Any high speed switch is capable of generating harmonics at frequencies that are many multiples of its basic operating frequency. It is the objective of a good installation to contain or absorb the resultant emissions.

All wiring is capable of acting as a receiving or transmitting antenna. Wiring should be arranged to take maximum advantage of the structural metal work inherent in most vehicles. Vehicle metalwork should be electrically linked with conductive braids.

## 6.1 Power Cables

All cables should be routed within the vehicle framework and kept as low in the structure as is practical – a cable run within a main chassis member is better screened from the environment than one routed through or adjacent to an overhead guard. Power cables should be kept short to minimize emitting and receiving surfaces. Shielding by the structure may not always be sufficient – cables run through metal shrouds may be required to contain emissions. Parallel runs of cables in common circuits can serve to cancel emissions – the battery positive and negative cables following similar paths is an example.

Tie all cables into a fixed layout and do not deviate from the approved layout in production vehicles. A re-routed battery cable could negate any approvals obtained.

## 6.2 Signal Cables

All wiring harnesses should be kept short. Wiring should be routed close to vehicle metalwork. All signal wires should be kept clear of power cables or made from screened cable. When using screened cable, make sure only to earth it to one point! Control wiring should be kept clear of power cables when it carries analogue information – for example, accelerator wiring. Tie all wiring securely and ensure wiring always follows the same layout.

## 6.3 Controller

Thermal and EMC (emissive) requirements tend to be in opposition. Additional insulation between the controller assembly and the vehicle frame work reduce capacitive coupling and hence emissions but tend to reduce thermal ratings. A working balance needs to be established by experiment. The complete installation should be documented, in detail, and faithfully reproduced on all production vehicles. When making changes, consider their effect on compliance ahead of any consideration of cost reduction or other “improvement”.

## 7 CALIBRATOR

### 7.1 The Calibrator

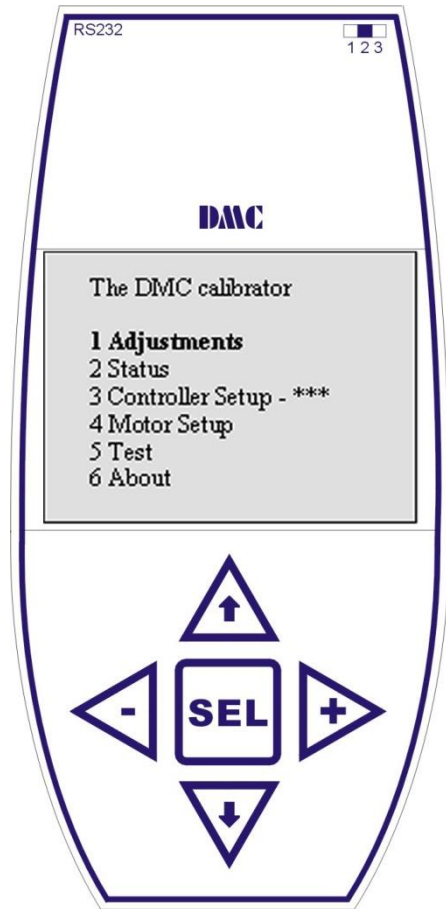

#### General

The DMC Calibrator is designed for Setting up the SuperSigma2 controller range. It also has a build-in interface calibrator software updates via USB. This guarantees maximum flexibility and no waste of hardware when only the software must be updated.

#### CAN Node Setup

When connecting the Calibrator to a controller it will 'scan' the CAN bus for all available Nodes, to enable calibration of all DMC controllers on the same bus. All controllers are by factory default set to Node 0. Therefore before using this feature, give all controllers on the bus a unique Node number. To do this, the calibrator must be plugged in to the controller you want to adjust the Node number on (menu item 9.1)

#### Adjustments

The calibrator is easy to use. The up and down buttons are used for scrolling up and down. Selections can be made with the SEL-button. The plus- and minus-buttons are used to increase or decrease the parameters.

#### Firmware updates

On the top-right-hand side a 3-way switch is used to select the operating mode. For normal operation it must be in position 2.

For flashing new calibrator firmware the switch must be moved to position 3. To be able to update the calibrator firmware it is necessary to have a PC software package installed and a copy of the calibrator firmware.

For detailed information on updating firmware please contact your DMC supplier. SuperSigma2 controller firmware updates are done with a separate dongle, please contact DMC for details.

### 7.2 Calibrator map

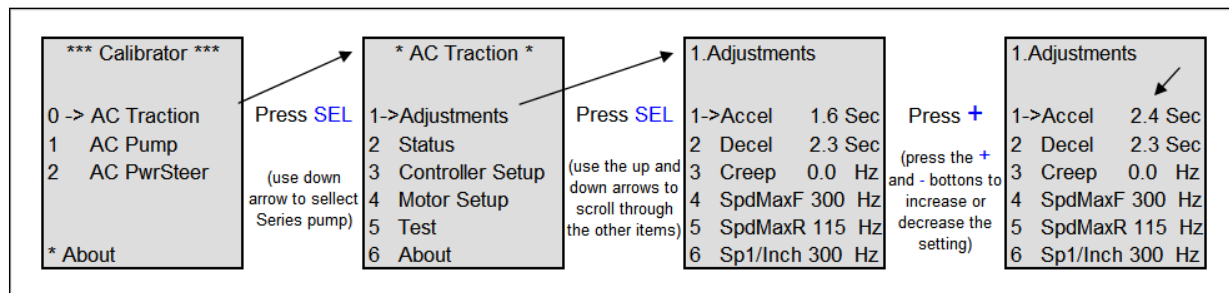

- Press and hold the select button for 3 seconds to return to the first screen.
- The calibrator remembers the cursor position in the submenus until key-off.
- When connecting more than 1 node to the CAN bus, the calibrator will react slightly slower.

### 7.3 DMC PC Programmer

The PC programmer is available for download from our website in the download section (register first).

To be able to use the PC programmer software, the latest version of the DMC calibrator with USB connectivity is required. The PC programmer let you edit, store and print controller parameters on a windows based PC running XP, Vista or Windows7. All SuperSigma2 controllers are compatible with the PC programmer.

The installation package includes a manual describing the features and functionality.

The PC programmer updates it's data dictionary automatically when new parameters are available. For the automatic update of the data dictionary on Windows Vista, 7 and 8, the DMC PC programmer must be started as administrator.

## 8 DASHBOARD DISPLAY

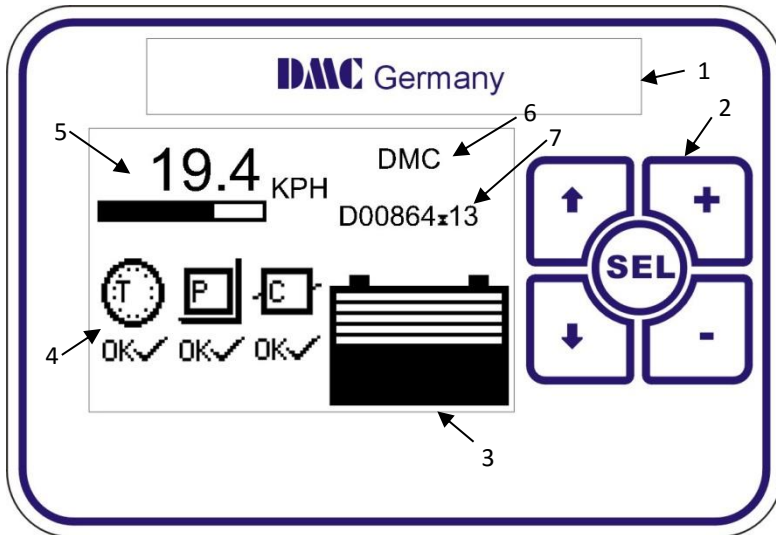

The DMC dashboard display is specially designed to be as flexible as possible to meet customer requirements.

The display is CAN-Bus driven and gets its information from the DMC controllers and eventually from auxiliary equipment.

In the future the membrane buttons will allow selecting different performance settings to be selected.

Faults are indicated with Icons. The Icons can be modified and even the customer's brand name and logo can be displayed to match the truck-identity.

### 8.1 General information

- <1> Brand name window. When required DMC can fit the customer's name and logo here during production.
- <2> Membrane buttons. Used for setting functions as Service interval timer, Hours counter and the Customer information field <6>.
- <3> Battery Discharge Indicator. Indicates the battery discharge state set by CAN-Node 0 (master)
- <4> Fault indication fields. Indicates the status of the traction- and pump controllers and other CAN-Nodes. The CAN node number is displayed in the Icons to indicate which controller has a problem. When a fault is indicated it replaces the 'OK' below the CAN-Node indicator with a fault icon. Via the calibrator it is possible to select what failure types are displayed or ignored.
- <5> General indication field. Calibrator selectable indicators for speed, motor voltage, accelerator demand and steering (from master)
- <6> Free 2x9 character field to show a text. The text can be edited with the display buttons.
- <7> Hours counter. Here either Work or Key hours are displayed, selectable with the display buttons. The hours counter value is stored in the display. The controllers have their own separate counter.

### 8.2 Display setup menu

To access the display setup menu, hold the select button for 3 seconds.

Features as the Service interval timer, Hours counter and the Customer information field can be adjusted and optionally protected with a pin code.

Use the up and down arrows (↑↓) to choose the option, press **SEL**, then use the + and - buttons to change the value.

### 8.3 Display Features Setup

Ref	Parameter	Submenu ref.	Sub menu description	Range & Action
1	Service timer	1. Svc interval	Set the time interval for next service. (40 Hours before service is needed a spanner icon is shown at power up indicating service is required)	0– 32767 Hr.
		2. Count hours	Set to count work or key hours	Work / Key Hrs.
		3. Reset timer	Resets the service interval timer	To confirm press <b>SEL</b>
		4. Svc time	Indication of the actual counter value	Indication only
2	Hours counter	1=Key, 2=Work	Select to indicate work or key hours	Select ↑↓ and confirm <b>SEL</b>
3	Information field	1. Adjust field	Free 2x9 character field to show a customised text.	↑↓ for position, + / - change value, <b>SEL</b> to return to menu
		1. Service timer	Sets pin code for service timer access	
4	Pin codes	2. Information field	Sets pin code for information field access	(Only with DMC master code)
		3. Reset all pin codes	Reset all pin codes	
5	About	SW version & date	Indication of the software version & date	Indication only
6	Return to main screen	-	Select to return to the main menu	Select ↑↓ and confirm ( <b>SEL</b> )

## 8.4 Display Icons

LED code	Calibrator Message	Display Icon
0	None (lowest priority)	OK ✓
	Handbrake on	
2	Voltage getting low	
3	Pump inhibit	
4	Voltage getting high	OK ✓ U ↑
5	Motor hot	
6	Controller hot	
7	Adjustments out of range	
8	Default settings restored	
9	E-eprom cannot be accessed	
10	2 Direction fault	
11	Seat- or tiller switch open	
12	Sequence fault	
13	Accelerator high at first power up	
14	Inching or belly fault	
15	Voltage too low	
16	N/A	
17	Voltage too low	
18	High sided Mosfet short circuit	
19	N/A	
20	Hardware over current	
21	Contactors coil short circuit	
22	Voltage too high	
23	Low sided Mosfet short circuit (neutral)	
24	HWFS not working	
25	Contactors fault	
26	Thermal shutdown fault	
27	Low side Mosfet short circuit	
28	Wire off detected	
29	CAN Node time out	
30	Over speed	
31-40	Motor fault	

## 9 Parameters

### 9.1 Menu 1 “Traction Adjustments”

Cal Ref	Parameter	Calibrator text	Min. adjust	Max. adjust	Step size	Default
1	Acceleration delay	Accel	0.1 s	10.0 s	0.1 s	2.5 s
2	Deceleration delay	Decel	0.1 s	10.0 s	0.1 s	0.3 s
3	Creep speed	Creep	0.0 Hz	10.0 Hz	0.1 Hz	0.0 Hz
4	Maximum speed forward	SpdMaxF	0.0 Hz	400.0 Hz	0.1 Hz	100.0 Hz
5	Maximum speed reverse	SpdMaxR	0.0 Hz	400.0 Hz	0.1 Hz	100.0 Hz
6	Cutback speed 1	Speed1	0.0 Hz	400.0 Hz	0.1 Hz	100.0 Hz
6a	Inching speed	InchSpd	0.0 Hz	25.0 Hz	0.1 Hz	10.0 Hz
7	Cutback speed 2	Speed2	0.0 Hz	400.0 Hz	0.1 Hz	100.0 Hz
7a	Inching time	InchTime	0.1 s	10.0 s	0.1 s	5.0 s
8	Cutback speed 3	Speed3	0.0 Hz	400.0 Hz	0.1 Hz	100.0 Hz
9	Speed limit ramp (torque control only)	SpLimRmp	0.1 s	10.0 s	0.1 s	4.0 s
10	Direction Brake torque	DBrake	0 %	100 %	1 %	85 %
11	Neutral Brake torque	NBrake	0 %	100 %	1 %	25 %
12	Foot brake torque	FBrake	0 %	100 %	1 %	65 %
13	Direction brake ramp time	DBrkRamp	0.1 s	10.0 s	0.1 s	3.0 s
14	Neutral brake ramp time	NBrkRamp	0.1 s	10.0 s	0.1 s	0.3 s
15	Foot brake ramp time	FbrkRamp	0.1 s	10.0 s	0.1 s	0.3 s
16	Drive torque release time	DTrqRLS	0.1	1.0 s	0.1	0.3
17	Brake torque release time	BTrqRLS	0.1	1.0 s	0.1	0.3
18	Neutral brake-End delay	NBrkEnd	0.0 s	10.0 s	0.1 s	0.0 s
19	Power steer delay	PStrDly	0.0 s	50.0 s	0.1 s	5.0 s
20	Electric brake delay	EBrkDly	0.0 s	50.0 s	0.1 s	0.5 s
21	Accelerator pot minimum	AccMin	0.0 V	10.0 V	0.1 V	0.2 V
22	Accelerator pot maximum	AccMax	0.0 V	10.0 V	0.1 V	4.6 V
23	Brake pot minimum	BrkMin	0.0 V	10.0 V	0.1 V	0.2 V
24	Brake pot maximum	BrkMax	0.0 V	10.0 V	0.1 V	4.6 V
25	Steer pot minimum	StrMin	0.00 V	10.00 V	0.01 V	0.20 V
26	Steer pot middle point	StrMid	0.00 V	10.00 V	0.01 V	2.30 V
27	Steer pot maximum	StrMax	0.00 V	10.00 V	0.01 V	4.80 V
28	Wig/Wag fwd threshold	FwdTH	0.0 V	10.0 V	0.1 V	3.0 V
29	Wig/Wag rev threshold	RevTH	0.0 V	10.0 V	0.1 V	2.0 V
30	Speed ratio (display Kph)	SpdRatio	1.0	999.9	0.1	120.0
31	Vehicle max. Speed	VmaxSpd	0.0 KPH	999.9 KPH	0.1 KPH	20.0 KPH
32	Dual motor cut out	DMcut	0 %	100 %	1 %	10 %
33	Dual motor angle 1	DMang1	0 %	100 %	1 %	60 %
34	Dual motor angle 2	DMang2	0 %	100 %	1 %	70 %
35	Dual motor angle 3	DMang3	0 %	100 %	1 %	85 %
36	Dual motor speed 1	DMspd1	0 %	100 %	1 %	10 %
37	Dual motor speed 2	DMspd2	0 %	100 %	1 %	5 %
38	Dual motor speed 3	DMspd3	0 %	100 %	1 %	30 %
39	Speed threshold to enter speed control	SpdThSpC	0.1 %	50.0%	0.1%	5.0%
40	Ramp time from SpdThSpC to zero	SpdRmpTm	0.0 S	10.0 S	0.1 S	2.5 S
41	Speed threshold to enter hill hold	SpdTH_HH	0.1 %	10.0 %	0.1 %	1.0 %
42	Hill hold time	HHTime	0 s	60 s	1 s	5 s
43	Restraint hill hold speed	HHspeed	0.0 Hz	5.0 Hz	0.1 Hz	3.0 Hz
44	Restraint hill hold torque threshold	HHTrqTH	0.1 %	35.0 %	0.1 %	1.5 %
45	Hill Hold/positioning proportional gain	KpPos	0.0	10.0	0.1	0.0
46	Hill Hold/positioning derivative gain	KdPos	0.00	1.00	0.01	0.00
47	Hill Hold position dead band	PosDBand	0	720	1	0



Depending on controller type and configuration some settings will be not available (N/A).

### 9.1.1 Neutral braking setup options

Neutral braking can be setup in three different modes, depending on the vehicle requirements.

The neutral braking mode can be selected in combination with the control mode setup in the controller setup menu:

- Control mode 0, speed control is selected with neutral braking operating in speed mode.
- Control mode 1, torque mode is selected with neutral braking operating in torque mode.
- Control mode 2, torque mode is selected with the end neutral braking operating in speed mode.

If the Hill-Hold feature is required, the choice for the end of neutral braking in speed mode is mandatory.

### 9.1.2 Neutral braking setup in speed control mode (control mode 0)

This feature is under development.

### 9.1.3 Neutral braking setup in torque control mode (control mode 1)

The following graph shows how the available neutral braking parameters work.

Use this graph as a reference to understand the meaning of the different parameters used to setup smooth neutral braking to zero speed.

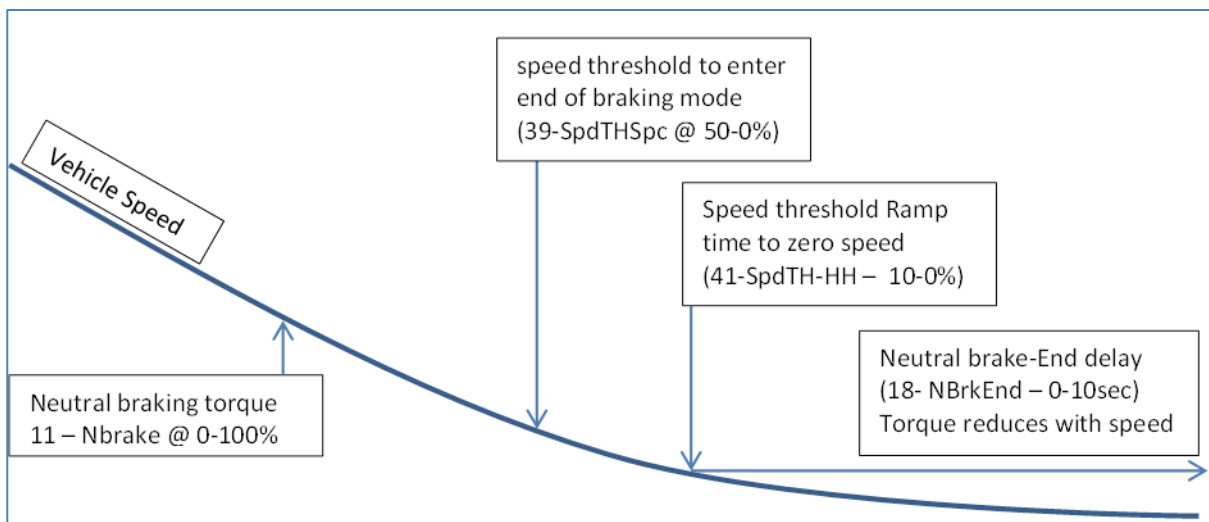

The neutral braking torque is set with parameter 1.11 (typical value between 10 and 25%). The torque is ramped with parameter 1.14 Neutral brake ramp time (typical set to 2 to 4 seconds). When 'speed threshold to enter end of braking mode' is reached the neutral braking torque will be reduced with speed to give a smooth end of braking feel (typical value 10 to 14%). From the point 'speed threshold ramp time to zero speed' (typical 2 to 5%) a timer function (neutral brake end delay – typical 5 to 10 seconds) is used to brake the vehicle to zero speed.

### 9.1.4 Neutral braking setup in torque control mode (control mode 2)

This feature is under development.

### 9.1.5 Hill Hold

If the Hill-Hold feature is required, the choice for 'end of neutral braking in speed mode' is mandatory.

This feature is under development.

## 9.2 Menu 1 “Pump Adjustments”

Cal Ref	Parameter	Calibrator text	Min. adjust	Max. adjust	Step size	Default
1	Acceleration delay	Accel	0.1 s	10.0 s	0.1 s	2.5 s
2	Deceleration delay	Decel	0.1 s	10.0 s	0.1 s	0.3 s
3	Creep speed	Creep	0.0 Hz	10.0 Hz	0.1 Hz	0.0 Hz
4	Maximum pot speed 1	Potmax1	0.0 Hz	400.0 Hz	0.1 Hz	0.0 Hz
5	Speed 2 demand	Pspeed2	0.0 Hz	400.0 Hz	0.1 Hz	0.0 Hz
6	Speed 3 demand	Pspeed3	0.0 Hz	400.0 Hz	0.1 Hz	0.0 Hz
7	Speed 4 demand	Pspeed4	0.0 Hz	400.0 Hz	0.1 Hz	0.0 Hz
8	Speed 5 demand	Pspeed5	0.0 Hz	400.0 Hz	0.1 Hz	0.0 Hz
9	Speed 6 demand (power steer)	Pspeed6	0.0 Hz	400.0 Hz	0.1 Hz	0.0 Hz
10	Minimum motor speed in cutback conditions (usually for hydraulic pump protection)	MinSpeed	0.0 Hz (Disabled)	400.0 Hz	0.1 Hz	0.0 Hz
11	Acceleration delay for speed 6 demand (pwrStr)	Paccel6	0.1 s	10.0 s	0.1 s	2.5 s
12	Power steer delay	PStrDly	0.1 s	50.0 s	0.1 s	5 s
13	Accelerator pot minimum	AccMin	0.0 V	10.0 V	0.1 V	3.3 V
14	Accelerator pot maximum	AccMax	0.0 V	10.0 V	0.1 V	0.2 V
15	Speed threshold to enter speed control	SpdThSpC	0.1 %	50.0%	0.1%	5.0%
16	Ramp time from SpdThSpC to zero	SpdRmpTm	0.0 S	10.0 S	0.1 S	2.5 S
17	Speed threshold to enter hill hold	SpdTH_HH	0.1 %	10.0 %	0.1 %	1.0 %
18	Hill hold time	HHTime	0 s	60 s	1 s	5 s
19	Restraint hill hold speed	HHspeed	0.0 Hz	5.0 Hz	0.1 Hz	3.0 Hz
20	Restraint hill hold torque threshold	HHTrqTH	0.1 %	35.0 %	0.1 %	1.5 %



Depending on controller type and configuration some settings will be not available (N/A).

### 9.3 Menu 2 “Status”

The status menu shows various parameters from the controller which can be useful to help tune and optimize vehicle performance.

Cal Ref	Item	Calibrator text	Step size	Service log info & Notes			
1	Drive hours counter	Drive	0.1 Hrs	▶	shows key hours		
2	Battery Discharge Indicator	BDI	1 %	◀	Raw BDI value incl. state (WO & CO)	▶	BDI states (see BDI States table)
3	Vehicle Speed	Vehicle	1 Kph				
4	Controller Temperature	CtrlTmp	0.1 °C	◀	Min. temperature	▶	Max. temperature
5	Motor Temperature	MotTemp	0.1 °C		Shows N/A when disabled.		
6	Battery Voltage	BatVolts	0.1 V			▶	Max. Voltage
7	Capacitor Voltage	CapVolts	0.1 V			▶	Max. Voltage
8	Accelerator demand	Accel	0.1 %	◀	Steer pot demand	▶	Foot brake demand
9	Drive State	DriveSta	--		See drive and brake status table		
10	Speed Limit	SpeedLim	--		See speed limits table		
11	Torque Limit	TrqLimit	--		See torque limits table		
12	Motor Limit	MotorLim	--		See motor limits table		
13	Current Fault code	CurFault	Fxx	◀	Show fault time	▶	Show sub code
14	Target demand	DemTrgt	0.1 %	+	CW	-	CCW
15	Ramped demand	DemRampd	0.1 %	+	CW	-	CCW
16	Actual torque	TrqAct	0.1 %	◀	Motor torque capability	▶	Sub code
				+	CW	-	CCW
17	Actual speed	SpeedAct	0.1 %	+	CW	-	CCW
18	Actual Flux	FluxDem	0.1 %			▶	Actual Flux
19	Stator speed	StatorSpd	0.1 Hz				
20	Rotor speed	RotorSpd	0.1 Hz			▶	RPM speed
21	Motor current	I_Motor	0.1 Arms	◀	Id Current	▶	Iq Current
22	Motor voltage	V_Motor	0.1 Vrms	◀	Reactive Power	▶	Motor Power
				-!	Reached maximum output voltage (VL)		
23	Battery current	I_batter	0.1 A				
24	Filtered capacitor voltage	V_CapFlt	0.1 V				
25	Speed limit	SpdLim	0.1 %				
26	Drive torque limit	DrvTrqL	0.1 %			▶	Torque limit CW
27	Brake torque limit	BrkTrqL	0.1 %			▶	Torque limit CCW



To reset the service log data, press the + and – button at the same time when the controller is in neutral.



### 9.3.1 Status tables

#### BDI States

BDI States	Description
0	Initializing
1	OK
2	BDI is getting low → Warning (WO)
3	BDI is too low → Cut out (CO)

#### Drive and brake status

Status	Description
NC	No Configuration
N	Neutral, not pulsing
FD	Forward drive
RD	Reverse drive
DB	Direction braking
NB	Neutral braking
FB	Foot braking
FB	Hill hold
HF	Forward restraint hill hold
HR	Reverse restraint hill hold

### 9.3.2 Drive and brake limits tables

Torque limits have precedence above speed limits.

#### Speed limits

+

Limit	Description
MS	Motor speed
SM	Speed limit forward or reverse
S1	Speed 1 limit
S2	Speed 2 limit
S3	Speed 3 limit
S4	Speed 4 limit
S5	Speed 5 limit
S6	Speed 6 limit
SI	Inching
SB	BDI speed limit

#### Torque limits

Limit	Description
CT	Controller temperature
MT	Motor temperature
PT	Performance table current limit
TC	Timed Current Limit
T1	$I^2t$ current limit step 1
T2	$I^2t$ current limit step 2
T3	$I^2t$ current limit step 3
HV	High Voltage limit
LV	Low Voltage limit

#### Motor Limits

Limit	Description
TL	Torque Limit
SL	Speed Limit
TH	Not able to hold torque
SH	Not able to hold speed
FH	Not able to hold flux
IH	Not able to hold flux current
CH	Not able to hold circle limitation
HL	Not able to hold hexagon limit
OL	Circle limitation

#### Shared Line Contactor Status

Status	Description
ST	Starting up
RC	Ready to close Line Contactor
CS	Is closing line contactor
PS	Start pulsing
KF	Key fault is found
NK	Not known

## 9.4 Menu 3 “Controller Setup”

### 9.4.1 Controller Setup for Traction

Change these settings to select the required options and I/O.

Cal Ref	Parameter	Calibrator text	Options (defaults are in bold)	Range
1	Accel. Characteristic	Lin/Curv	<b>0 = Accelerator linear</b> 1 = Accelerator curved	0 – 1
2*	Control mode	Spd/Torq	0 = Speed mode <b>1 = Torque mode</b> 2 = Torque mode & end of braking in speed mode	0 – 2
3	Proportional direction brake	Off /Bpro	0 = Fixed, <b>1 = Proportional</b>	0 – 1
4	Hill hold	Off/HH	<b>0 = Coast</b> , 1 = Hill hold	0 – 1
5*	I/O Pin 5 and 6	Spd/Inch	<b>0 = Speed 1+2</b> , 1 = Inching Fwd/Rev	0 – 1
6	I/O Pin 7	Spd3/Hbk	0 = Speed3, <b>1 = Handbrake</b> (If handbrake selected, set the required max. speed when handbrake applied at Speed 3)	0 – 1
7	Power steer trigger	PsF/FR/S	<b>0 = FS1</b> 1 = Fwd/Rev 2 = Seat switch 3 = FS1 and rotor speed	0 – 3
8*	Vehicle type select	Ride/Wlk	<b>0 = Ride-on</b> 1 = Walkie 2 = Walkie (allows to drive slowly @ speed 3 speed with tiller switch open and only when speed 3 is active)	0 – 2
9*	Tiller Function	TillFunc	<b>0 = Normal response</b> 1 = fast response 2 = immediate response	0 – 2
10	Display Status field	Of/D/V/K	0 = None 1 = Acc 2 = Motor V/RPM <b>3 =Speed in Kph</b> 4 = Steering position 5 = Motor current 6 = Battery current	0 – 6
11*	Accelerator type	AccelTyp	<b>0 = Normal accelerator</b> , 1 = Wig-wag	0 – 1
12	Accelerator Damping Factor (Torque mode only)	AccelDam	<b>1 = No damping</b> , 2 to 120 multiplies the acceleration and deceleration delay, linear reduced to 1 at 75% demand.	1 - 120
13*	Single or Dual Motor	Si/DL/DR	<b>0 = Single</b> , 1 = Dual Left, 2 = Dual Right	0 – 2
14*	Digital O/P 4 config	RL/BL	<b>0 = Remote LED</b> , 1 = Brake light	0 – 1
15*	Load Defaults	LoadDefs	<b>0 = Don't load defaults</b> , 1 = Load defaults	0 – 1
16*	Active low or high digital inputs	Actv L/H	<b>0 = Active low digital inputs</b> 1 = Active high digital inputs	0 – 1
17*	Accelerator supply wire off detection	SplyWrOf	<b>0 = No supply wire off detection</b> 1 = 0V wire off detection enabled 2 = 5V wire off detection enabled 3 = Both 0V and 5V wire off detection	0 – 3
18	Standby timer	StdByDly	Adjustable from 0 to 10 Minutes. <b>Default is 0 (0=Off)</b>	0 - 10
19	Line Contactor pull-in level	LCPIInLv	Adjustable from 50% to 100% Ubatt.to limit inrush current. <b>Default is 75%</b>	50-100%
20	Line Contactor pull-in time out	LCPIInTO	Line Contactor pull in time out.. <b>Default is 10sec.</b>	0-60sec
21	Drive torque during braking	DTrq@Brk	<b>0 = no drive torque allowed during brake</b> 1 = drive torque is allowed during brake	0 - 1



- (\*) Recycle the key switch to make changes active. (Also indicated on calibrator 'key')
- Irrelevant options show n/a

### 9.4.2 Controller Setup for Pump

A pump controller is always in speed control mode. Other changes to the Controller Setup compared to the traction controller setup are:

Cal Ref	Parameter	Calibrator text	Options (defaults are in bold)	Range
1	Accelerator Characteristic	Lin/Curv	0 = linear, 1 = Curved	0 - 1
2	Speed 6 input normally closed (low) or normally open (high)	Spd6NO/NC	0 = Speed 6 input normally closed <b>1 = Speed 6 input normally open</b>	0 – 1
3	Inhibit input normally closed (low) or normally open (high)	HibNO/NC	<b>0 = Inhibit input normally closed</b> 1 = Inhibit input normally open	0 – 1
4	Enable power up checks	Nchk/Chk	<b>0 = Disable power up checks</b> 1 = Enable power up checks	0 – 1
5	Enable pot with switch	NoSw/Sw	<b>0 = Disable pot switch (use pot only)</b> 1 = Enable pot with switch	0 – 1
6	Display Status Field	Of/D/V/K	0 = None 1 = Acc 2 = Motor V/RPM <b>3 = Speed in Kph</b> 4 = Steering position 5 = Motor current 6 = Battery current	0 – 6
7	n / a			
8	n / a			
9	Digital O/P 4 (pin A18)	RemoteLED	<b>0 = Remote LED</b>	0 – 0
10	Load Defaults	LoadDefs	<b>0 = Don't load defaults</b> , 1 = Load defaults	0 – 1
11	Active low or high digital inputs	Actv L/H	<b>0 = Active low digital inputs</b> 1 = Active high digital inputs	0 – 1
12	Accelerator supply wire off detection	SplyWrOf	<b>0 = No supply wire off detection</b> 1 = 0V wire off detection enabled 2 = 5V wire off detection enabled 3 = Both 0V and 5V wire off detection	0 – 3
13	Line Contactor pull-in level	LCPIInLv	Adjustable from 50% to 100% Ubatt.to limit inrush current. <b>Default is 75%</b>	50-100%
14	Line Contactor pull-in time out	LCPIInTO	Line Contactor pull in time out.. <b>Default is 10sec.</b>	0-60sec



- (\*) Recycle the key switch to make changes active. (Also indicated on calibrator 'key')
- Irrelevant options show n/a

## 9.5 AC Motor Auto Tuning

The SuperSigma2 is capable of performing automatic tuning of the motor parameters. The auto tuning system is designed to optimize the motor parameters completely automated without the need to tune anything manually. The auto tuning just needs a basic set of parameters that are normally provided on the nameplate of the motor manufacture. After starting the auto tuning procedure, the motor will spin. It is essential to make sure the motor can spin freely and unloaded. Under these circumstances the best possible tuning results will be achieved.

Alternatively we designed an auto tuning procedure that can be used in situations where it is impossible to let the motor spin unloaded, for example when the hydraulic pump is installed and can't be removed.

If the alternative auto tuning procedure is used, the tuning results will not be as perfect as in a unloaded situation.

	<ul style="list-style-type: none"> <li>• <b>Traction controller auto tuning: THE TRACTION WHEELS MUST BE OF THE GROUND</b></li> <li>• <b>Pump controller auto tuning: REMOVE THE HYDRAULIC PUMP</b></li> </ul>
---	--

The auto tuning takes about 5 minutes to complete.

After a successful auto tuning, all the parameters in the motor setup and motor advanced menu will have new values. Although not advised, it is possible to modify parameters in the AC motor setup menu. In that case a recalculation must be performed to make sure the parameters are matching. Please read the next section for more details.

Parameters in the advanced menu are for indication only and cannot be changed manually without the assistance of DMC engineers.

### 9.5.1 Setting up auto tuning

The following table indicates what is required to achieve good auto tuning results.

The required input data can be found on the motor name plate.

Auto Tuning Parameter	Acceptable auto tuning results	Best auto tuning results
Number of motor poles	Required	
Number of sensor encoder teeth	Required	
Sensor encoder supply voltage	Choose 5 volt or 12 volt sensor supply	
Reverse sensor encoder reading	Try set to 1 if auto tuning diagnostics return an error 6 and the actual motor direction is forward	
Reverse motor direction	Try set to 1 if auto tuning diagnostics return an error 6 and motor direction is reversed (or counter clock wise)	
Nominal Battery Voltage	Required	
Nominal RMS motor current For tuning	Optional	Required
Maximum RMS motor current	Optional (or enter best guess) (set higher than nominal current!)	Required
Nominal frequency for auto tuning	Optional	Required
Maximum desired motor frequency	Optional (or guess... freq.x30=rpm)	Required
Auto tuning type	Set to 0 - for regular unloaded auto tuning Set to 1- only for tuning an pump motor with the hydraulic pump fitted.	

It is not preferred, but even if not all of the above information is available, it is still possible to perform auto tuning.

The auto tuning algorithm will try to calculate the missing parameters instead.

As a minimum - the number of poles, the number of teeth, the nominal battery voltage must be set manually!

**Nonetheless, to get the best possible tuning results, all auto tuning parameters should be set properly!**

#### 9.5.1.1 Special note for auto tuning hydraulic pump motors

The user must verify if the motor is spinning the pump in the right direction (otherwise change the motor direction with parameter 'reverse motor direction'.

### 9.5.2 Menu 4 “AC Motor Auto Tuning”

Cal Ref	Parameter	Calibrator text	Min.	Max.	Step size	Default
1	Number of motor poles	Nmotpole	2	16	2	4
2	Number of sensor encoder teeth	NofTeeth	16	255	1	80
3	Sensor encoder supply voltage	SenSuppV	0 (=5V)	1 (=12V)	1	0
4	Reverse sensor encoder reading	SpdRever	0	1	1	0
5	Reverse motor direction	MotorRev	0	1	1	0
6**	Battery Voltage	BattV AT	12.0 V	Units $U_{\max\text{nom}}$	1V	24V
7**	Nominal RMS motor current For tuning	Inom AT	1 Arms	Units $I_{\max}$ Arms	1 Arms	½ max current
8*	Maximum RMS motor current	Imotmax	1 Arms	Units $I_{\max}$ Arms	1 Arms	Max current
9**	Nominal motor frequency	Fnom AT	0.0 Hz	400.0 Hz	0.1 Hz	50.0 Hz
10*	Maximum desired motor frequency	Fmotmax	0.0 Hz	400.0 Hz	0.1 Hz	100.0 Hz
11	Start Auto-tuning	AutoTune	0	1	1	0
12	Recalculation after changing one of the adjustment of this menu signed with one star *	Recalcul	0	1	1	0
13	Auto Tuning Type: 0= Standard <u>unloaded motor</u> auto tuning 1= Alternative <u>loaded motor</u> auto tuning (only to be used for hydraulic pump motors) (Tuning results will not be perfectly optimized)	TuneType	0	1	1	0



- **\* If a parameter with one star is changed, recalculation is required.**  
Recalculation is performed after setting the recalculation parameter to 1 and recycling the key.
- **\*\* Changes to parameters with two stars are only considered when performing auto tuning after recycling the key !**

### 9.5.3 Initiating auto tuning

After setting up the basic parameters for the auto tuning, the auto tuning can be started. This is done by setting the auto tuning parameter to '1'. The calibrator will now show the following screen.:

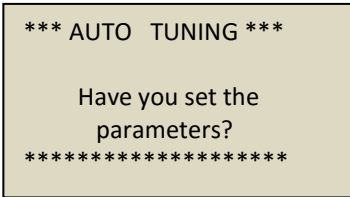

These screens are shown to alert the user auto tuning is starting.

This can be confirmed by pressing and holding the + and - button for at least 5 seconds.

Then the calibrator shows the following screen:

For Traction controllers:

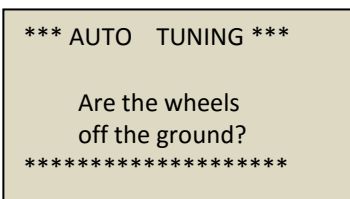

For Pump controllers:

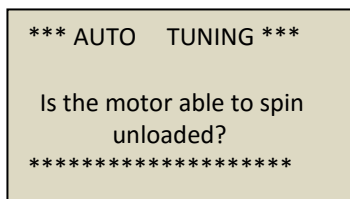

Again, confirm by pressing and holding the + and - button for at least 5 seconds.

When Auto Tuning has started the following screen is shown:

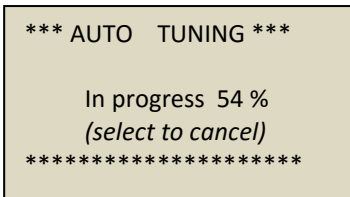

**Auto tuning can be disabled anytime by pressing the select button.**

After the auto tuning process is finished the following screen will be shown:

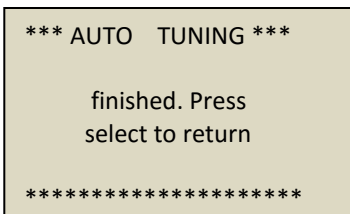

In case of errors the following screen will be shown:

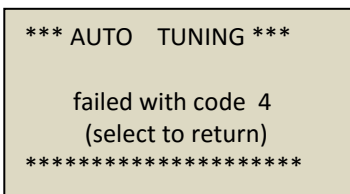

In case of an error, verify the error code in the next section.

### 9.5.4 Auto tuning errors

It is possible the auto tuning algorithm has encountered an error. This list provides the possible errors during auto tuning.

Error	Description
0	No errors in the Auto tuning Motor Module
1	The rated battery voltage set is not consistent with the measured one auto tuning cannot be performed
2	The battery is too low auto tuning cannot be performed
3	An overcurrent is detected (maybe short circuit or wrong wiring)
4	no current is flowing in the motor: no or wrong motor connection
5	No encoder feedback reading it means no encoder connected or motor locked (tip: check for the encoder supply voltage setting being correct)
6	Error in speed measurement: direction measured is not consistent with motor direction
7	Measured rotor frequency is very different from stator frequency (wrong number of pulses or poles)
8	Unable to finish calculation (rotor resistance too low or too high)
9	Unable to finish calculation (motor with very low inductance or very low rated current)
10	Unable to finish calculation (motor with very low rotor resistance or very low rated current or rated frequency for auto tuning set too low)
11	Unable to finish calculation (motor with very low magnetizing inductance or very low rated current or frequency for auto tuning set too low)
12	Unable to finish magnetizing curve calculation (motor is not load free)
13	Unable to finish auto tuning motor parameters calculation because flux demand is set too low => increase flux demand parameters
14	Unable to finish auto tuning motor parameters calculation because it is unable to find the frequency base point for field weakening within the set max. frequency → increase max. desired motor frequency parameter or increase nominal RMS motor current for auto tuning
15	Unable to finish auto tuning motor parameters calculation because values are out of range → Increase maximum desired motor frequency
16	Unable to finish auto tuning motor parameters calculation. Increase nominal motor frequency and perform auto tuning again
17	Unable to calculate PI GAINS (perform again auto tuning starting from default and check motor connection and if motor is free to spin)
18	An unknown error occurred

### 9.5.5 Recalculation

It is possible to alter one or more parameters, for example the maximum desired motor current. To gain advantage of this change it is possible to do another auto tuning, but it is also possible to perform a recalculation of the parameters based upon this change. To initiate a recalculation, simply set the parameter in the motor setup menu to 1 and recycle the key switch.

## 9.6 Menu 5 “AC Motor Setup”



The AC motor setup menu define the motor characteristics for the controller. These parameters are calculated by the auto tuning algorithm. If it is necessary to tune these parameters, please consult DMC first. Mistakes in the motor setup tables can cause serious accidents and/or defective controllers and/or defective motors.

Cal Ref	Parameter	Calibrator text	Min.	Max.	Step size	Default
1	Proportional gain speed controller	Kp Spd	0.1	63.9	0.1	14.0
2	Integral gain speed controller	Ki Spd	0.1	1999.9	0.1	9.0
3	Differential gain speed controller	KdSpd	0	80.0	0.1	0.0
4	Enable double PI settings for speed controller	SpdPlx2	0	1	1	1
5	Double PI speed threshold	SpdPITH	0 %	50 %	1 %	8 %
6	Proportional gain speed controller below threshold	KpSpdLow	0.1	63.9	0.1	8.0
7	Integral gain speed controller below threshold	KiSpdLow	0.1	1999.9	0.1	30.0
8	Differential gain speed controller below threshold	KdSpdLow	0	80.0	0.1	0.0
9	Transition time between the two PI settings for the speed controller	TransTim	0.01 s	5.00 s	0.01 s	0.3 s
10	Torque request at maximum flux request	Trq@Ymax	5 %	100 %	1 %	30 %
11	Minimum required percentage of rated flux at zero torque request	FluxMin	20 %	120 %	1 %	80 %
12	Extra field weakening level referred to the ideal flux at maximum speed	FWextra	0 %	40 %	1 %	0 %
13	Speed Threshold for beginning field weakening	F_FW TH	20 %	200 %	1 %	85 %
14	Torque Reduction Map in field weakening range point 1	TReduc1	10%	100%	1%	90%
15	Torque Reduction Map in field weakening range point 2	TReduc2	10%	100%	1%	80%
16	Torque Reduction Map in field weakening range point 3	TReduc3	10%	100%	1%	70%
17	Torque Reduction Map in field weakening range point 4	TReduc4	10%	100%	1%	60%
18	Torque Reduction Map in field weakening range point 5	TReduc5	10%	100%	1%	50%
19*	Slip Frequency	SlipFrq	0.01 Hz	12.00 Hz	0.01 Hz	Depend on Controller Size
20*	Maximum rated flux	FluxMax	20 %	120 %	1 %	100 %
21	Capacitor Voltage ramp Time	CapVTime	0.1 s	20.0 S	0.1 S	5.0 S
22	Voltage Limiter Filter Frequency	FVlimFlt	0.1 Hz	100.0 Hz	0.1 Hz	2.0 Hz
23	Circle limitation	VmodMax	92%	98%	1%	94%



- \* If a parameter with one star is changed, recalculation is required. Recalculation is performed after setting the recalculation parameter to 1 and recycling the key.



## 9.7 Menu 6 “AC Motor Advanced”

(indication only – not possible to modify without assistance of DMC engineers)

Cal Ref	Parameter	Calibrator text	Min.	Max.	Step size	Default
1	Decouple Iq and Id controllers	Decouple	0	1	1	0
2	Enable speed filter for flux / torque observer	SpdFiltr	0	1	1	0
3	Enable software PWM algorithm delay compensation	PWMDelay	0	1	1	1
4	Limit torque controller during Voltage limiting	VoltSat	0	1	1	1
5	Temperature Rising Compensation	RrAdapta	0	1	1	0
6	Speed Control Filter	SCFilter	0	1	1	1
7	Enable Voltage Limiter	VoltCtrl	0	1	1	1
8	Enable Flux Controller	FluxCtrl	0	1	1	1
9	Speed filter cut-off frequency	Fspdfilt	4 Hz	400 Hz	1 Hz	80 Hz
10	Filter frequency for the flux regulator	FfluxFit	1 Hz	100 Hz	1 Hz	50 Hz
11	Minimum level of flux for minimum flux protection	FluxminF	0 %	60 %	1 %	5 %
12	Timer for minimum flux protection intervention	FluxTime	0.05 s	1.50 s	0.01 s	0.2 s
13	Percentage of correction for leakage inductance value	DecoLeak	20 %	180 %	1 %	100 %
14	Back EMF correction factor	BEMFCorr	20 %	180 %	1 %	100 %
15	Enable Capacitor voltage Variation compensation	CapVCmEn	0	1	1	1

## 9.8 Menu 7 “Limits Setup”

Cal Ref	Parameter	Calibrator text	Min.	Max.	Step size	Default
1	Motor Temp Sensor Type	MtempTyp	0	0	0	0= KTY84-130
2	Motor Temp. Cutback start	TempStrt	0 °C	151 °C (disables)	1 °C	120 °C (enabled)
3	I <sup>2</sup> t Nominal Motor Current	NomCurr (I2tInom)	0 Arms	Unit max.	1 Arms	0 Arms
4	I <sup>2</sup> t Start Motor Temperature	I2tTemp	0 °C	100 °C	1 °C	0 °C
5	I <sup>2</sup> t Time	I2tTime	0 s (disables)	999 s	1 s	0 s (disabled)
6	I <sup>2</sup> t Cutback1	I2tCutB1	0 %	100 %	1 %	100 %
7	I <sup>2</sup> t Cutback2	I2tCutB2	0 %	100 %	1 %	100 %
8	I <sup>2</sup> t Cutback3	I2tCutB3	0 %	100 %	1 %	100 %
9	Performance Table Speed 1	PTSpd1	0.0 Hz (disables)	400.0 Hz	0.1 Hz	50.0 Hz
10	Performance Table Speed 2	PTSpd2	0.0 Hz	400.0 Hz	0.1 Hz	70.0 Hz
11	Performance Table Speed 3	PTSpd3	0.0 Hz	400.0 Hz	0.1 Hz	100.0 Hz
12	Performance Table Cutback 1	PTCutBk1	0 %	100 %	1 %	100 %
13	Performance Table Cutback 2	PTCutBk2	0 %	100 %	1 %	100 %
14	Performance Table Cutback 3	PTCutBk3	0 %	100 %	1 %	100 %
15	Low Voltage Cut Back start threshold	LVCBstrt	16.0 V	Unit max.	0.1 V	20.0 V
16	Low voltage cut back end threshold	LVCBend	16.0 V	Unit max.	0.1 V	16.0 V
17	Low voltage error threshold	LVerror	14.0 V	Unit max.	0.1 V	14.0 V
48 V units						
18	High Voltage Cut Back start threshold	HVCBstrt	24.0 V	67.5 V	0.1 V	60.0 V
19	High voltage cut back end threshold	HVCBend	24.0 V	67.5 V	0.1 V	67.5 V
20	High voltage error threshold	HVerror	24.0 V	70.0 V	0.1 V	70.0 V
96 V units						
18	High Voltage Cut Back start threshold	HVCBstrt	24.0 V	138.5 V	0.1 V	130.0 V
19	High voltage cut back end threshold	HVCBend	24.0 V	138.5 V	0.1 V	138.5 V
20	High voltage error threshold	HVerror	24.0 V	140.0 V	0.1 V	140.0 V
Generic						
21	Absolute motor speed	AbsMaxSp	0.0 Hz	400.0 Hz	0.1 Hz	125.0 Hz
22	torque threshold for stall protection (off when 100%)	TrqTHLim	1 %	100 %	0,1 %	100 %
23	timer for stall protection	StallTim	0 s	120 s	0,1 s	60 s



## 9.9 Menu 8 “BDI” Battery Discharge Indicator

Cal Ref	Parameter	Calibrator text	Min. adjust	Max. adjust	Step size	Default 48V	Default 96V
1	Battery type	Batt Typ	0	0	1	0	0
2	Nominal battery voltage	NomBatV	12.0 V	$U_{absmax}$	1 V	48 V	96 V
3	BDI reset level	BDIreset	12.0 V	$U_{absmax}$	0.1 V	50.2 V	100.3 V
4	BDI empty level	BDIempty	12.0 V	$U_{absmax}$	0.1 V	38.9 V	77.8 V
5	BDI warning level	BDIwarn	0 %	100 %	1 %	20 %	20 %
6	BDI cut out level	BDIcut	0 %	100 %	1 %	0 %	0 %
7	BDI speed limit (traction only)	BDIspeed	0.0 Hz	400.0 Hz	0.1 Hz	100.0 Hz	100.0 Hz

## 9.10 Menu 9 “CAN Bus Setup”

SuperSigma2 uses our own CAN bus protocol for sending information to other CAN nodes and receiving control messages from other CAN nodes. The system is designed for the SuperSigma2 to act as a slave in an existing CAN environment. Detailed information about the protocol will be provided on request.

As default the CAN system is deactivated.

Cal Ref	Parameter	Calibrator text	Options	Default
1	CAN Node Number	CAN node	Node number <b>0</b> to 15	0
2	CAN bit rate	CANbitRt	CAN bus speed: <b>0 = 100kbps</b> 1 = 125kbps 2 = 250kbps	0
3	Transmit CAN messages  Used short descriptions:  DC : drive command (receive) DS : drive status (transmit) MS : Motor status (transmit) CS : controller status (transmit)	CANMsgs	0= DC & DS (Receive & Transmit) 1 = DC & DS & MS (Receive & Transmit) 2 = DC & DS & CS (Receive & Transmit) 3 = DC & DS & CS & MS (Receive & Transmit) <b>4= no CAN message</b> 5= DS only (Transmit only) 6= MS only (Transmit only) 7= DS & MS (Transmit only) 8= CS only (Transmit only) 9= CS & DS (Transmit only) 10= CS & MS (Transmit only) 11= CS & MS & DS (Transmit only)	4
4	Shared Line Contactor	ShareLC	<b>0 = No shared line contactor</b> 1 = Shared line contactor	0
5	Last Node Sharing Line Contactor	LstNode	Node number <b>1</b> to 15	1
6	CAN motor status transmit rate	CAN_MS	100 to 1000ms	100ms
7	CAN controller status transmit rate	CAN_CS	100 to 1000ms	1000ms
8	CAN drive status transmit rate	CAN_DS	100 to 1000ms	100ms
9	CAN controller timeout timer	CAN_TO	100 to 500ms	150ms



Recycle the key switch to make changes active. (Also indicated on calibrator ‘key’)

## 9.11 Menu 10 “Fault Log”

The fault log remembers the last 10 faults and stores the key hours when the fault happened.

Holding the (-) button shows the registered hours counter time when the fault occurred.

Holding the (+) button shows the fault sub error code.

To reset the fault log, press the + and – button at the same time when the controller is in neutral.



To reset the fault log data, press the + and – button at the same time when the controller is in neutral.

## 9.13 Menu 11 “Test”

### 9.13.1 Test menu for Traction

The test menu shows I/O information, useful for fault finding.

Cal Ref	Parameter	Calibrator Text	Unit	Min. Display	Max. Display	◀	▶
1	Forward switch	Forward	Input	0	1		
2	Reverse switch	Reverse	Input	0	1		
3	FS1 / Belly switch	FS1/Bely	Input	0	1		
4	Seat / Tiller switch	Seat/Til	Input	0	1		
5	Speed 1 / Inch Forward	Spd1/InF	Input	0	1		
6	Speed 2 / Inch Reverse	Spd3/InR	Input	0	1		
7	Speed 3 / Handbrake	Spd3/Hbk	Input	0	1		
*8	Digital Output 1	DigOut 1	Output	0	1		
9	Accelerator pot (%)	AccelPot	% Input	0 %	100 %		
10	Accelerator pot (V)	AccelPot	V	0.0 V	10.0 V	Raw AD	Raw AD Volts
11	Brake pot (%)	BrakePot	% Input	0 %	100 %		
12	Brake pot (V)	BrakePot	V	0.0 V	10.0 V	Raw AD	Raw AD Volts
13	Steer pot (%)	SteerPot	% Input	0 %	100 %		
14	Steer pot (V)	SteerPot	V	0.00 V	10.00 V	Raw AD	Raw AD Volts
15	Line contactor	Line	Output	0	1		
16	Electric Magnet Brake contactor	ElecMbrk	Output	0	1		
17	Power steer contactor	PSteer	Output	0	1		
18	Speed Sensor	SpeedSen	Input	0	1		
19	Speed Sensor Direction	SpeedDir	Input/ output	0	1		
20	Encoder 3 input	Encoder3	Input	0	1		
21	Positive hardware overcurrent trip	PosOvrCr	Input	0	1		
22	Negative hardware overcurrent trip	NegOvrCr	Input	0	1		
23	Internal temperature sensor	IntTempS	°C	0.00 °C	120.00 °C	Raw AD	Raw AD Volts
24	Internal reference voltage	IntVref	mV	0 mV	3300 mV	Raw AD	
25	+5 V power supply	+5V	V	0.00 V	5.10 V	Raw AD	Raw AD Volts
26	+14 V power supply	+14V	V	0.00 V	14.00 V	Raw AD	Raw AD Volts
27	M1 current sensor output	I_M1	V	0.00 V	5.10 V	Raw AD	Raw AD Volts
28	M3 current sensor output	I_M3	V	0.00 V	5.10 V	Raw AD	Raw AD Volts
29	M1 voltage	M1 Volts	V	0.0 V	200.0 V	Raw AD	Raw AD Volts
30	N/A						
31	M3 voltage	M3 Volts	V	0.0 V	200.0 V	Raw AD	Raw AD Volts
32	Power PCB identification	PCB ID		0 h	F h		
33	Sensor supply output	SensSuppl	Output	0	1		

### 9.13.2 Test menu for Pump

Changes to the Test menu compared to the traction test menu are:

Cal Ref	Parameter	Calibrator Text	Unit	Min. Display	Max. Display	◀	▶
1	Speed 1 digital input	Speed1	Input	0	1		
2	Speed 2 digital input	Speed2	Input	0	1		
3	Speed 3 digital input	Speed3	Input	0	1		
4	Speed 4 digital input	Speed4	Input	0	1		
5	Speed 5 digital input	Speed5	Input	0	1		
6	Speed 6 digital input	Speed6	Input	0	1		
7	Inhibit digital input	Inhibit	Input	0	1		
*8	Digital Output 1	DigOut 1	Output	0	1		
9	Accelerator pot (%)	AccelPot	% Input	0 %	100 %		
10	Accelerator pot (V)	AccelPot	V	0.0 V	10.0 V	Raw AD	Raw AD Volts
11	N/A						
12	Analog input 2(V)	Analog 2	V	0.0 V	10.0 V	Raw AD	Raw AD Volts
13	N/A						
14	Analog input 3	Analog 3	V	0.0 V	10.0 V	Raw AD	Raw AD Volts
...	...	...	...	...	...	...	...
16	Digital output 2	DigOut 2	Output	0	1		

## 9.14 Menu 12 “Debug”

(indication only)

The debug menu is for internal DMC use only.

## 9.15 Menu 13 “About”

Cal Ref	Information Field	Example	
1	Customer name	Cust.	Standard
2	Application	App.	Standard
3	Controller type	Ctrl.	AC Traction
4	Software type	Swtyp	PAC960TL1-04
5	Software version	SW	V02.00.00
6	Software Date	Date	26-08-2014
7	Hardware type	HWtype	Size 4 96 V
8	Hardware BOM	HWbom	V6.01b
9	BSP Version	BSP	V01.00.00
10	AC FOC version	ACFOC	V02.00.00

## 9.16 Available Application Notes

The following application notes are available upon request.

AN	Title	Version
120301	Flashing SuperSigma2 Controllers	V1.0
130101	Performance Table	V1.0
130102	$I^2t$	V1.0
130301	Low and High Voltage Limits and Cut Back	V1.0
CAN	DMC SuperSigma2 CAN protocol	V2.0
CAN	SuperSigma2 CAN Messages	V2.0
	Dual Motor Setup (document under development)	
	Shared line contactor setup (document under development)	

## 9.17 Thermal Motor Management & Performance Table

The Performance Table sets a maximum current for a specified speed as shown in the table below:

Speed	Maximum current allowed
Between PTSpd1 and PTSpd2	Scale the set maximum current proportionally with speed between the speed points PTSpd1 and PTSpd2.
Between PTSpd2 and PTSpd3	Scale the set maximum current proportionally with speed between the speed points PTSpd2 and PTSpd3.

The Performance Table collaborate with the other current roll back functions. The current roll back on controller temperature, current roll back on motor temperature and the  $I^2t$  function.

The  $I^2t$  function have its settings in percentages, the same as the current roll back on controller and motor temperature. The function that has the highest roll back percentage, will be applied to the applicable maximum current, and will result in the effective maximum current as shown in the picture below (here the roll back is 50%).

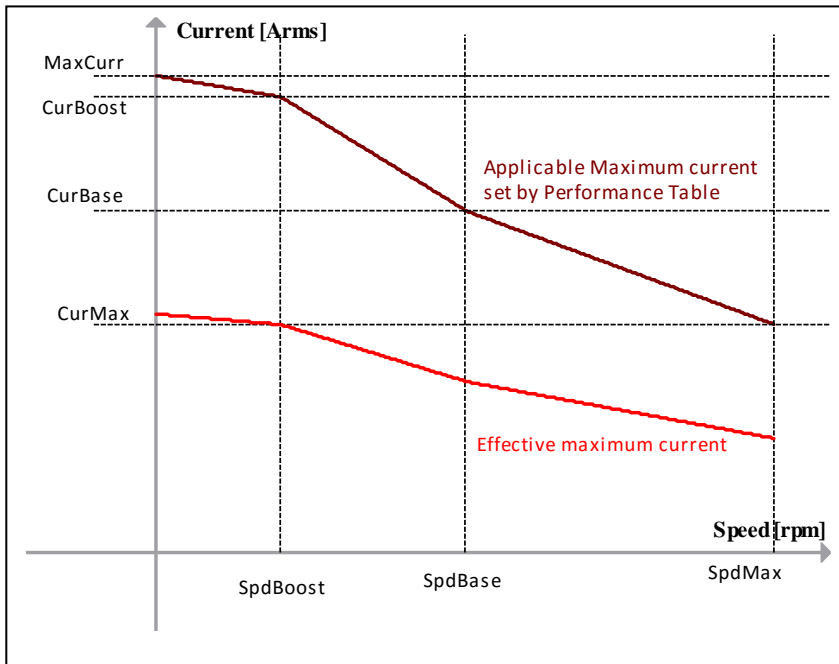

For normal operation, the maximum current at boost speed is usually set the same as the maximum current from the adjustments menu. This will then give a straight line from zero speed towards boost speed yielding maximum current at low speeds. During operation, the controller will show "PT" at row 9 in the status menu.

### 9.17.1 Current roll back on motor temperature

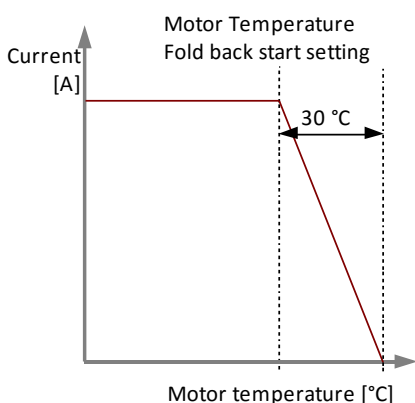

The maximum current value is rolled back as soon as the motor temperature is above it's starting point adjustment (parameter 2 in the limits setup menu). It is cut back proportionally between the starting point and 30 °C above the starting point as shown in the graph below.

### 9.17.2 Option to disable current roll back functions

To disable the current rollback features:

- current roll back on motor temperature; by setting the motor temperature start adjustment at 151 °C,
- $I^2t$  function; by setting the I2tTime adjustment to 0.
- Performance Table; by setting the maximum current at boost speed adjustment to 0 A.



## 10 Diagnostics

Base fault Code	Description	Sub fault code	Description
Controller warning faults - Reduces only performance - Fault will reset itself (if possible)			
0	No error	-	-
1	N/A	-	-
2	Voltage getting low	1	Battery voltage below absolute minimum
		2	Capacitor voltage below absolute minimum
		3	Battery voltage below minimum adjustment
		4	Capacitor voltage below minimum adjustment
3	Pump inhibit	-	-
4	Voltage getting high	1	Battery voltage above absolute maximum
		2	Capacitor voltage above absolute maximum
		3	Battery voltage above maximum adjustment
		4	Capacitor voltage above maximum adjustment
5	Motor temperature high	-	-
6	Controller temperature high	-	-
7	Adjustment out of range	< 999	First digit: menu number
		> 100	Last two digits: item number within menu
		999	Power PCB doesn't match firmware
		1	Shared LC : master is not shared line contactor
		2	Shared LC : slave is not shared line contactor
		3	Shared LC: not requested slave is shared LC
		4	Wigwag is selected without walkie
5	Inching and walkie are both selected		
6	Dual motor with speed mode selected		
8	Default adjustments used	-	-
Drive error faults - Commences graceful neutral brake - Requires a neutral recycle action to reset fault			
9	Memory chip fault	> 0	Report to DMC.
10	Both forward and reverse inputs active	-	-
11	Ride-on: Seat switch not closed or timed out	-	-
	Walkie: Tiller switch not closed		
12	Power up sequence fault	1	Traction: FS1 switch active at power up
		2	Traction: Forward switch active at power up
		3	Traction: Reverse switch active at power up
		4	Pump: Pump pot active at power up
		5	Pump: Speed 2 active at power up
		6	Pump: Speed 3 active at power up
		7	Pump: Speed 4 active at power up
		8	Pump: Speed 5 active at power up
		9	Inching: Forward switch active at power up
		10	Inching: Reverse switch active at power up
13	Accelerator more than 50% at power up	1	Normal accelerator type high at power up
		2	Wig-wag accelerator type high at power up
14	Traction: Inching sequence faults	1	Foward switch active at inching
		2	Reverse switch active at inching
		3	FS1 switch active at inching
		4	Seat switch active at inching
		5	Foot Brake switch active at inching
		6	Hand Brake active at inching
		7	Both inching buttons active at inching
		8	Inching buttons active during normal drive
	Walkie: Belly switch active	-	-

Errors are continued at next page...

Error codes continued

Base fault code	Description	Sub fault code	Description
<b>Soft error faults - Immediately stops pulsing - Requires a neutral recycle action to reset fault</b>			
15	Supply voltage too low	> 0	Report to DMC.
16	N/A	-	
17	Voltage is too low	1	Battery voltage below absolute minimum
		2	Capacitor voltage below absolute minimum
		3	Battery voltage below minimum adjustment
		4	Capacitor voltage below minimum adjustment
18	High sided mosfets short circuit	1	M1 mosfets
		2	M2 mosfets
		3	M3 mosfets
19	N/A	-	
<b>Hard error faults - Immediately stops pulsing and open line contactor - Cannot be reset (only by a key switch recycle)</b>			
20	Hardware over current detected	1	Positive overcurrent detected during initialization
		2	Negative overcurrent detected during initialization
		3	Positive overcurrent detected
		4	Negative overcurrent detected
		< 4	Contact DMC
21	Contactor coil driver fault (e.g. short circuit)	1 – 3	Line contactor coil short circuit
		4 – 6	EM-Brake contactor coil short circuit
		7 – 9	Power steer contactor coil short circuit
		10 – 12	Digital output 4 short circuit
22	Voltage is too high	1	Battery voltage above absolute maximum
		2	Capacitor voltage above absolute maximum
		3	Battery voltage above maximum adjustment
		4	Capacitor voltage above maximum adjustment
23	Low sided mosfets short circuit in neutral	1	M1 mosfets
		2	M2 mosfets
		3	M3 mosfets
24	Hardware fail safe fault	> 0	Report to DMC.
25	Line contactor fault	1	Could not discharge capacitor bank.
		2	Capacitor bank did not charge sufficiently to safely close the line contactor.
		3	Line contactor opened inadvertently.
26	Pump motor speed below minimum speed setting -when a system limit is active due to motor or controller power reduction	-	Let the system cool down for the power limit to become inactive.
27	Low sided mosfets short circuit during power up and before line contactor is closed	1	M1 mosfets
		2	M2 mosfets
		3	M3 mosfets

Errors are continued at next page...

Error codes continued

Base fault code	Description	Sub fault code	Description
28	Wire off	1	Quadrature encoder sensor wire off detected
		2	5 V supply wire off detected
		3	0 V supply wire off detected
		4	Wig-wag out of safety range
		5	Motor thermal sensor wire off detected
29	Node fault	1	Shared LC slave time out fault
		2	Shared LC Master fails to broadcast to slaves
		3	Shared LC requested slave is not found by
		4	Shared LC master time out fault
		5	CAN time out fault
		6	CAN security bit check failure
30	Motor over speeding	1	Motor speed is too high to commence safe pulsing
		2	Motor speed is higher than absolute maximum speed
31	Motor Fault	> 0	See table below "Generic AC Motor Module sub error codes"
32	Motor Module initialization error		
33	Motor Module configuration inconsistency		
34	Motor Module parameter inconsistency		
35	Motor Calibration initialization fault	1	Could not initialize calibration
		2	Time out during calibration
36 .. 38	N/A		
39	Generic time out	1	Time out on configuration upload
		2	Time out on getting stable inputs
		3	Time out on motor ready
≥ 40	System fault.	> 0	Report to DMC.

## 10.1 Generic AC Motor Module sub error codes

Sub Code	Description
0	No errors in the motor module
1	The motor module could not be initialized
2	The motor could not be fluxed in time
3	An overcurrent is detected
4	A wrong value of current offset is calculated
5	Wrong current: rated motor current is greater than max
6	Wrong poles number (is odd)
7	Wrong rated speed and/or frequency (slip is too high)
8	Wrong no load current: too near to motor current
9	Wrong motor power: is inconsistent with motor voltage, current, and power factor
10	Wrong settings: rated motor voltage is too high in relation with the battery voltage capability (0.93% $V_{batt}/\sqrt{2}$ )
11	Wrong settings: max trip current greater than max controller current
12	Wrong settings: max motor current lower than trip current
13	Wrong settings: min flux demand is greater than max flux demand
14	Wrong settings: min flux current demand is greater than max flux current demand
15	Unable to recalculate motor parameters because flux demand is set too low --> increase flux demand parameters
16	Unable to recalculate motor parameters because unable to find the frequency base point for field weakening within the set max frequency --> increase max. frequency parameter
17	Unable to re calculate motor parameters because flux is out of table --> perform auto tuning again
18	An unknown error occurred

## 11 Graphics & Schematics

### 11.1 Accelerator Characteristics

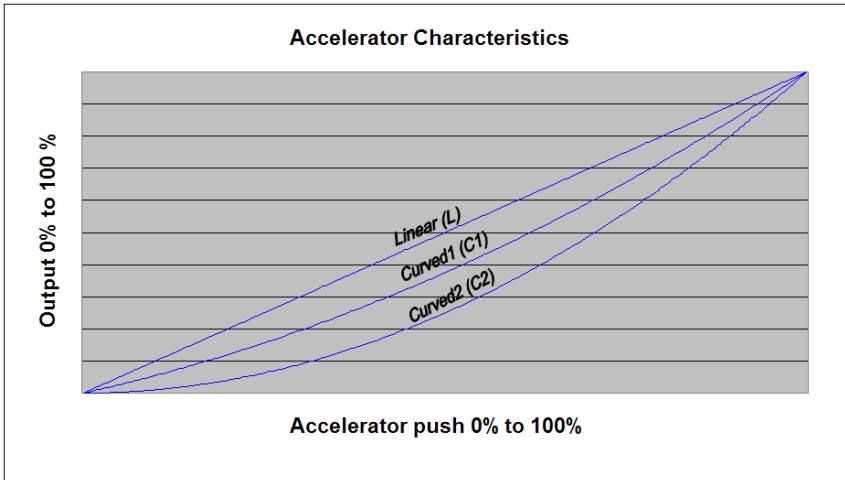

### 11.2 Controller Thermal Cutback Characteristic

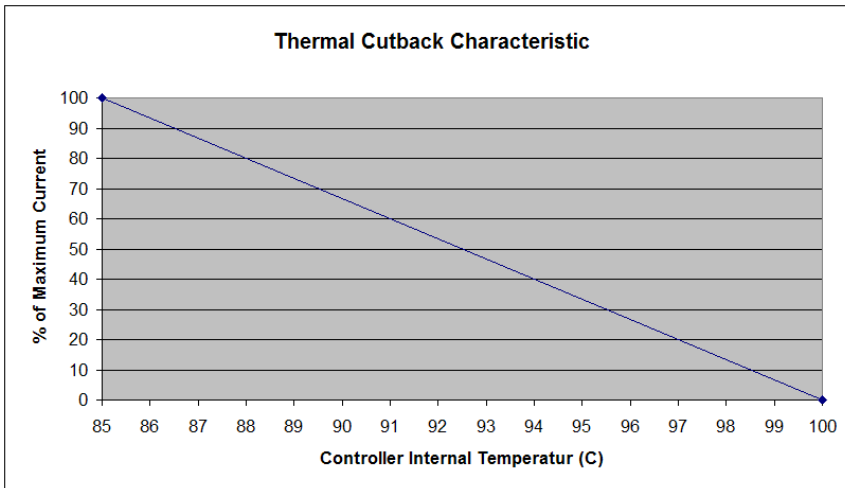

## 11.3 Light Wiring AC Traction

### Connector A - Vehicle Interface - 35 Way (AMP SEAL Series)

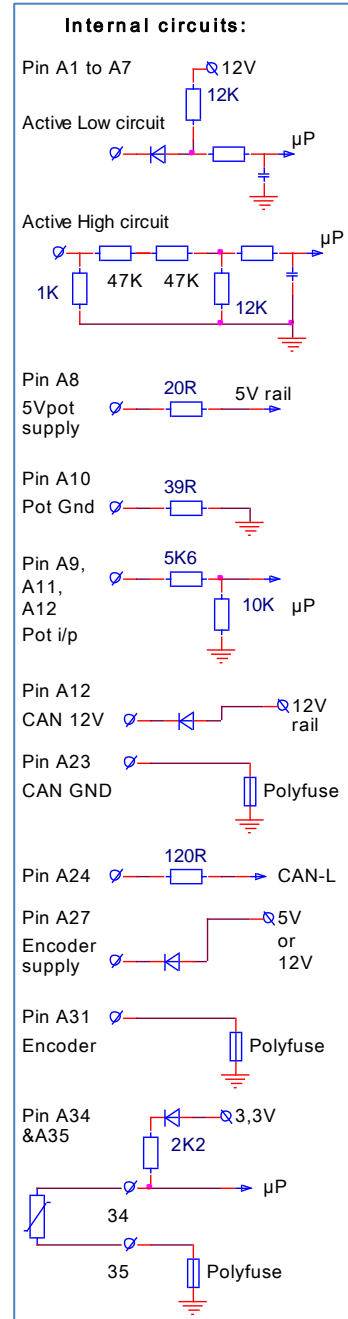
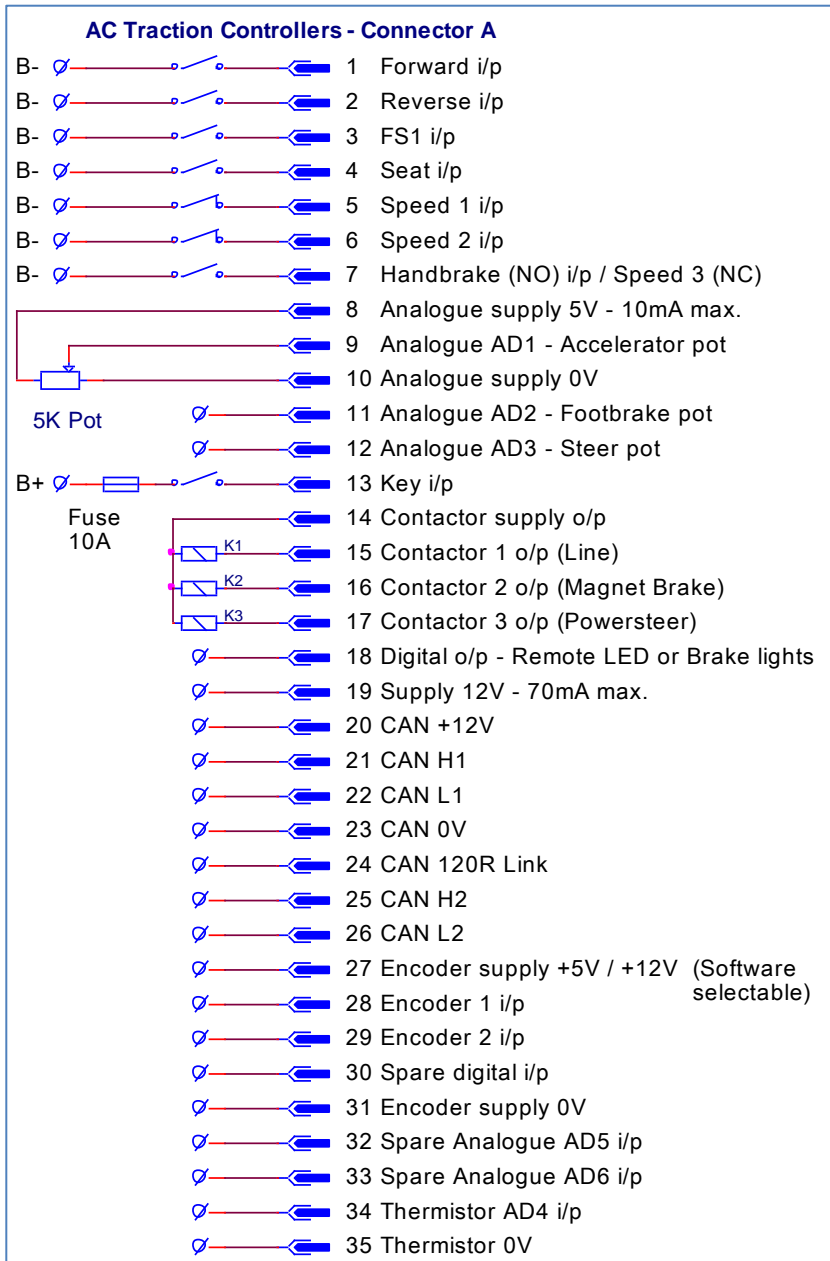

### Connector B - Communications - 8 Way

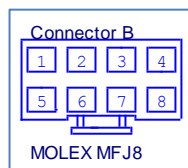
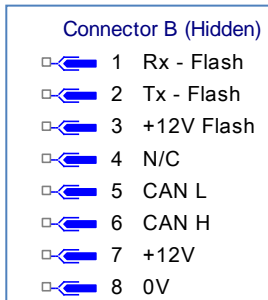

### 35 Way pin layout:

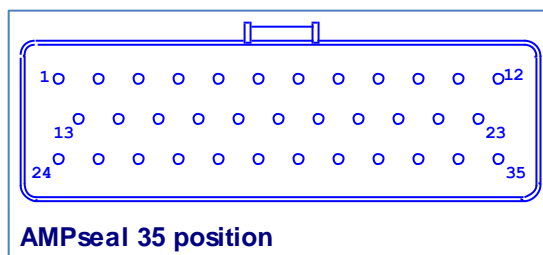

**Most inputs are Normally Open (NO) except for the speed inputs, these are Normally Closed (NC)**

## 11.4 Light Wiring AC Pump

### Connector A - Vehicle Interface - 35 Way (AMP SEAL Series)

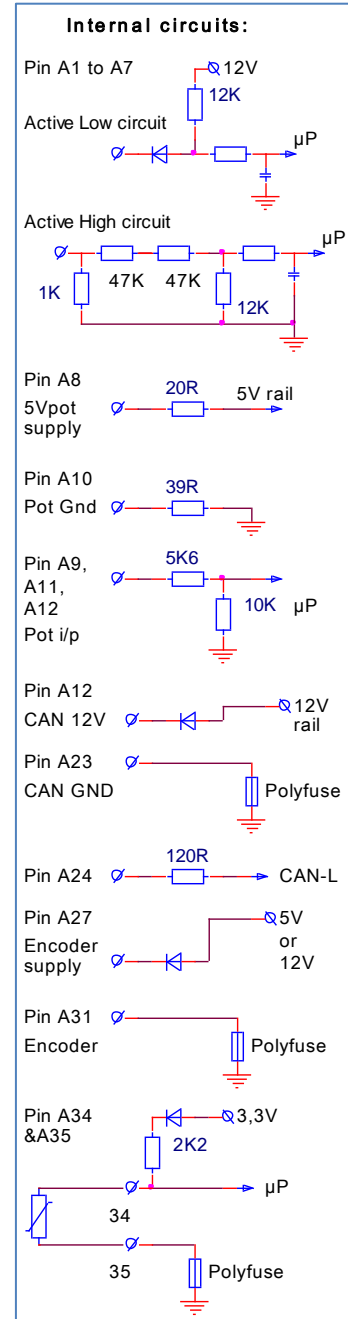
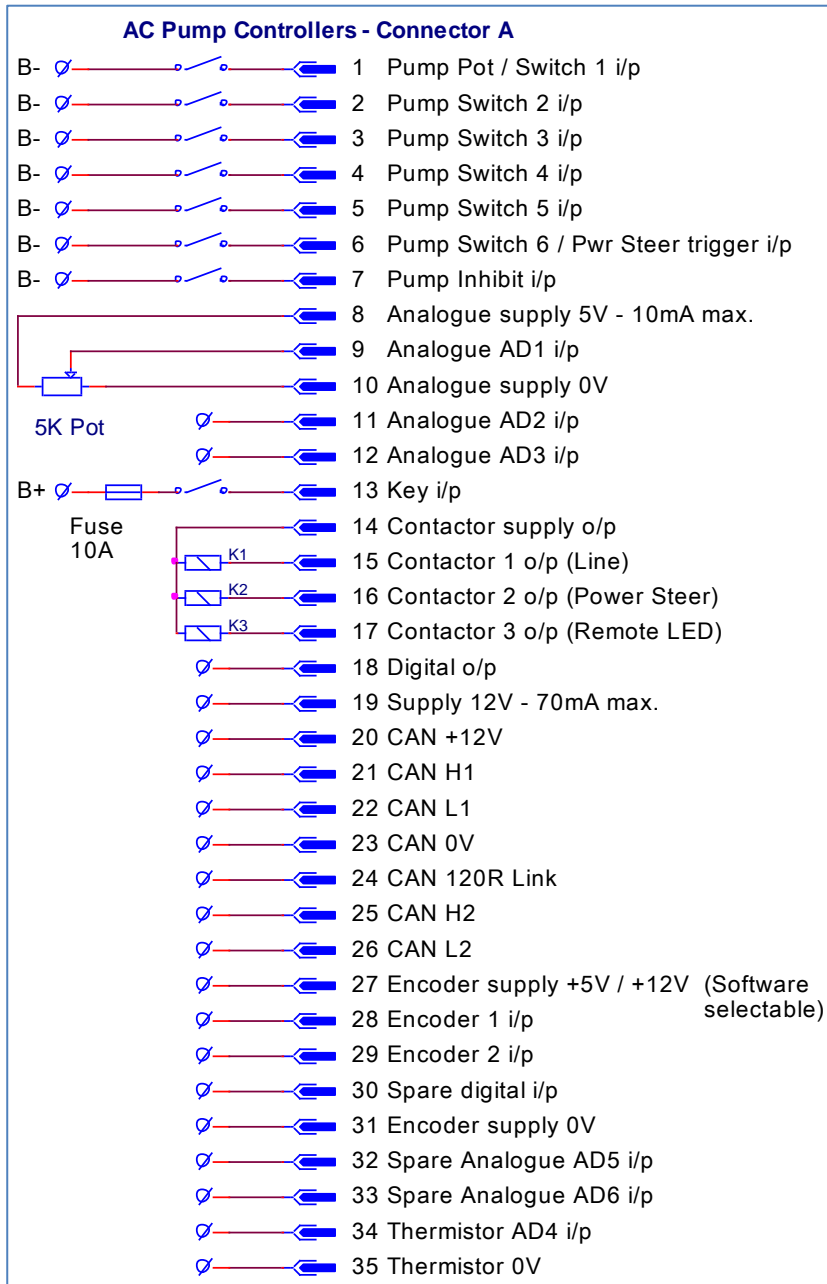

### Connector B - Communications - 8 Way

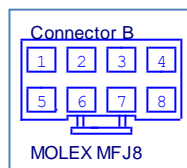
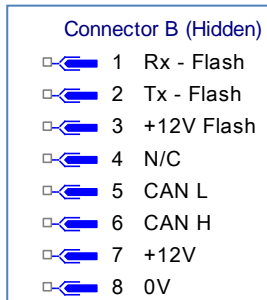

### 35 Way pin layout:

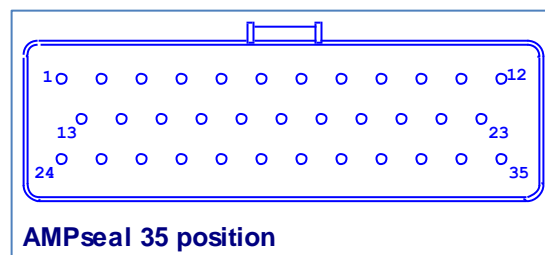

For pump controllers pump switch 6 and pump inhibit are standard active low. Via the setup menu it is possible to change to active high.

## 11.5 CAN bus wiring

CAN bus communication wires should be terminated at both ends with a 120Ω resistor.

All SuperSigma2 controllers the 120Ω termination resistor installed, it is up to the user to use it or not.

By linking pin A24 and A25 on a SuperSigma2 controller the termination resistor becomes active.

If a CAN bus network is installed in a machine, special care should be taken which 2 CAN nodes should have the build-in termination resistor connected. Make sure that only 2 termination resistors are active.

Below 2 examples of a CAN bus network, with and without DMC CAN Display.

### 11.5.1 CAN bus wiring example with DMC Display:

The DMC advanced display has a CAN bus termination resistor installed. This resistor is fixed installed and cannot be disconnected. Below schematic shows how the CAN bus termination should be wired when a DMC advanced display is part of the CAN bus installation:

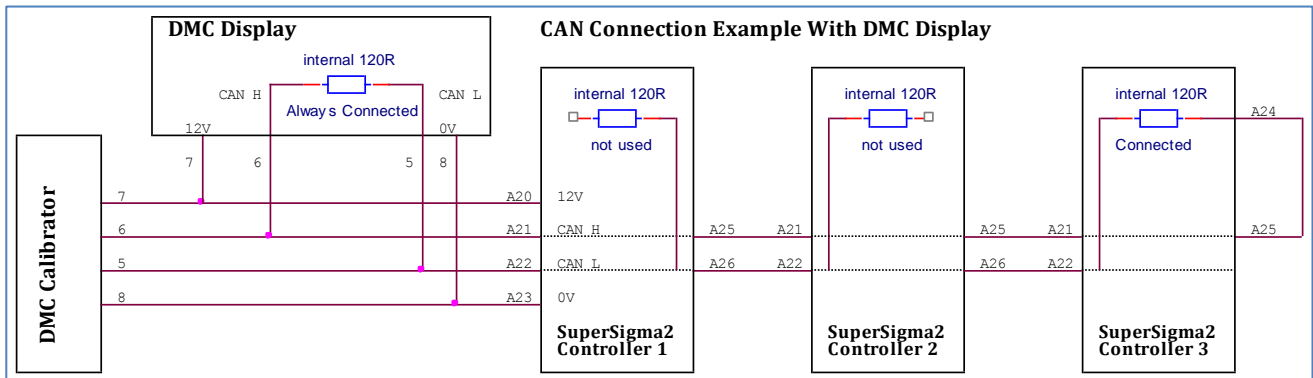

### 11.5.2 CAN bus wiring example without DMC Display:

If no DMC advanced display is installed, wire as followed:

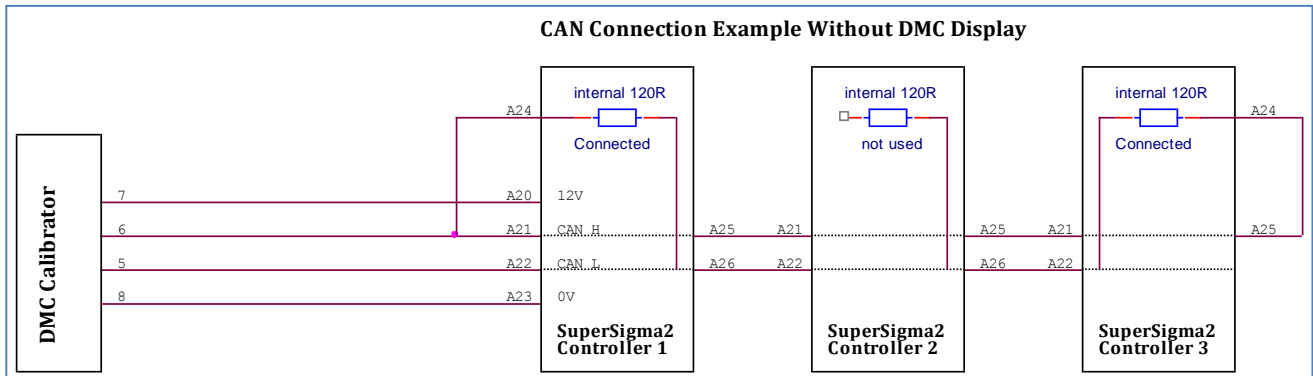

Always connect the 0V of the CANbus to the largest powercontroller in the system



## 11.6 iGauge Display - Connection diagram

The iGauge is a 52mm diameter indicator.

It is capable of indicating lead acid battery discharge state, hours counter and the main SuperSigma2 fault messages.

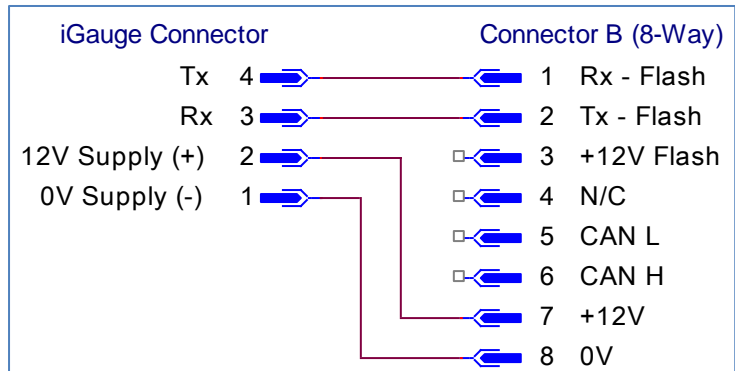

## 11.7 Power Wiring

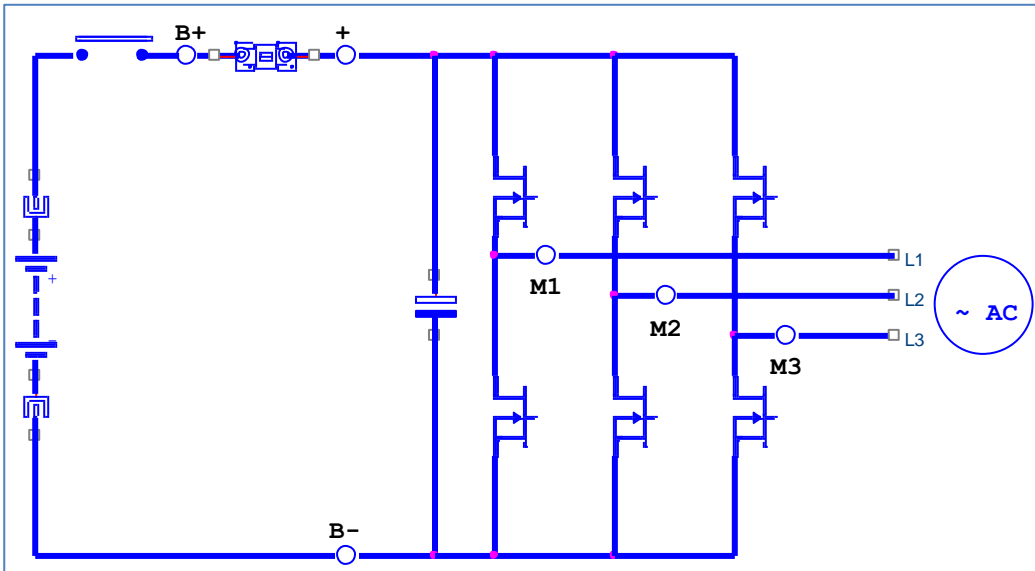

When an emergency battery disconnect switch is fitted, the key switch must be fed through an auxiliary switch to prevent over voltage damage due to disconnect during regen.

## 12 Mechanical Drawings

### 12.1 SuperSigma2 Controllers

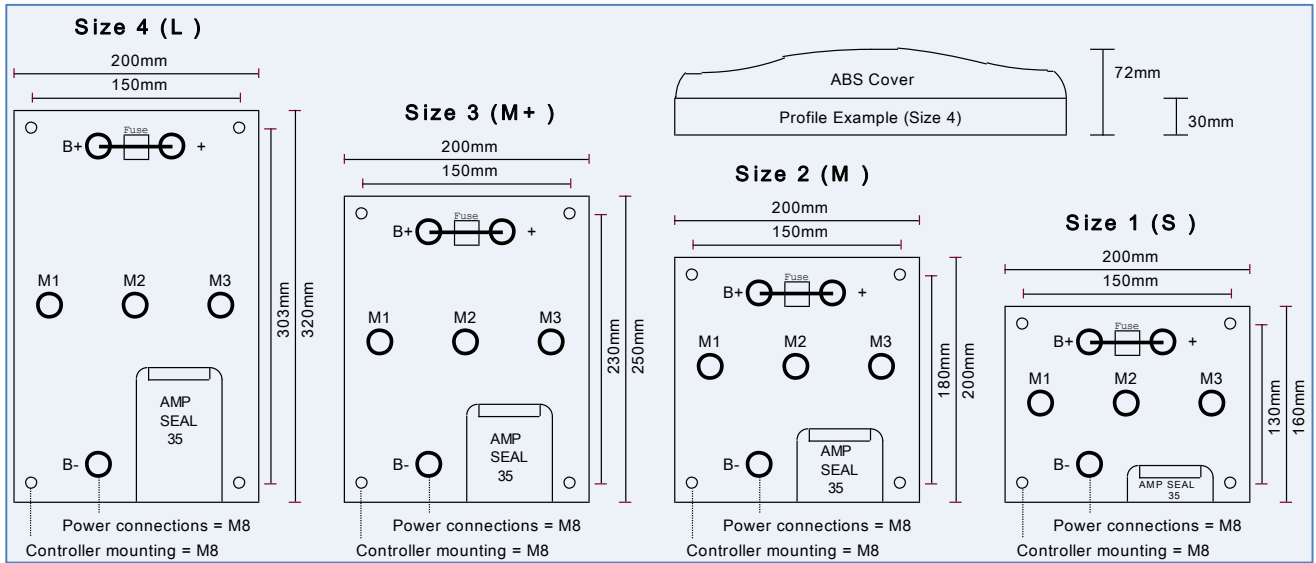

### 12.2 DMC Advanced Display

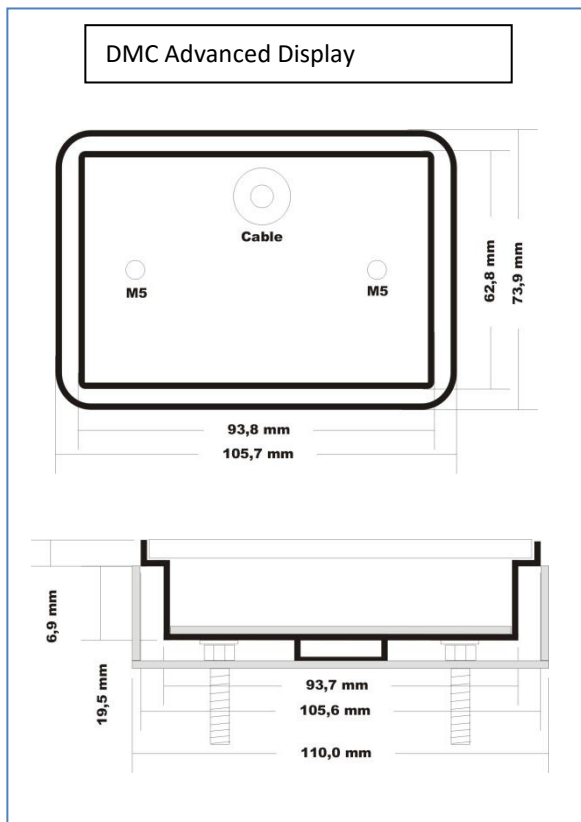

## 13 Contact information

DMC GmbH  
Auf dem Hochstück 11  
Herten Germany  
45701 Herten Germany  
Tel: +49 (0) 2366 10070  
Fax: +49 (0) 2366 100750  
Email: [info@dmcde.de](mailto:info@dmcde.de)  
Web: [www.dmcde.de](http://www.dmcde.de)